

# JURASSIC PARK

## CABINET SETUP GUIDE



Innovative Concepts in Entertainment  
10123 Main Street  
Clarence, New York 14031  
(716) 759-0360 Service  
[www.icegame.com](http://www.icegame.com)

## Table of Contents

Cabinet Setup	3 - 7
Back Seat Assembly	8 - 12
Diagnostic Menu System	13
Main Menu	14
Options	15
Gun Calibration	
Gun Assembly	16
Warranty	19

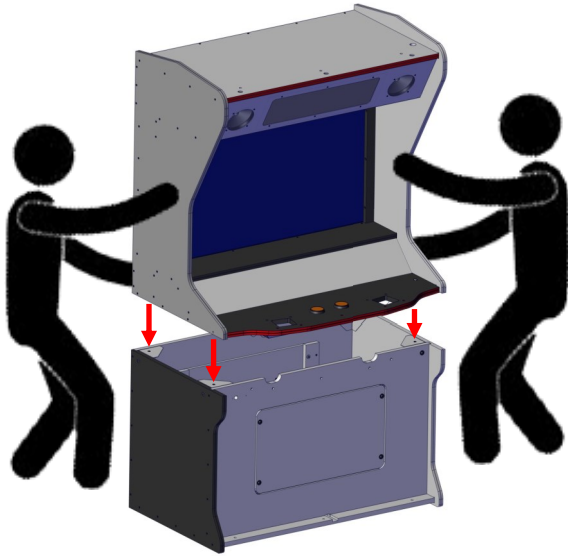

With a helper, place the upper main cabinet onto the lower cabinet.

At the front, install one AA6281 Allen and AA6212 washer on each side.

Do not fully tighten at this time.

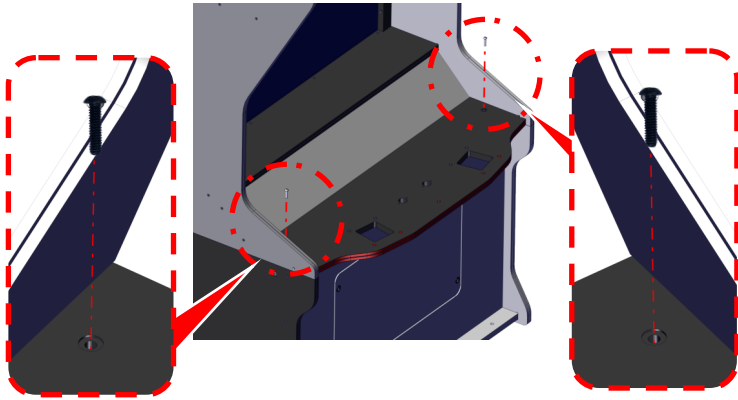
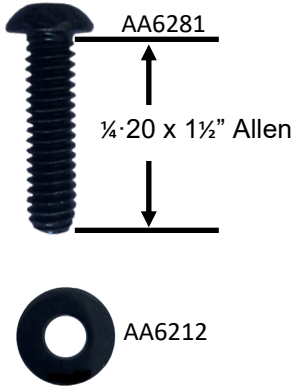

Remove the back panel. There are six AA6220 Allen bolts and AA6212 washers that hold the cabinet back panel on. Put hardware aside.

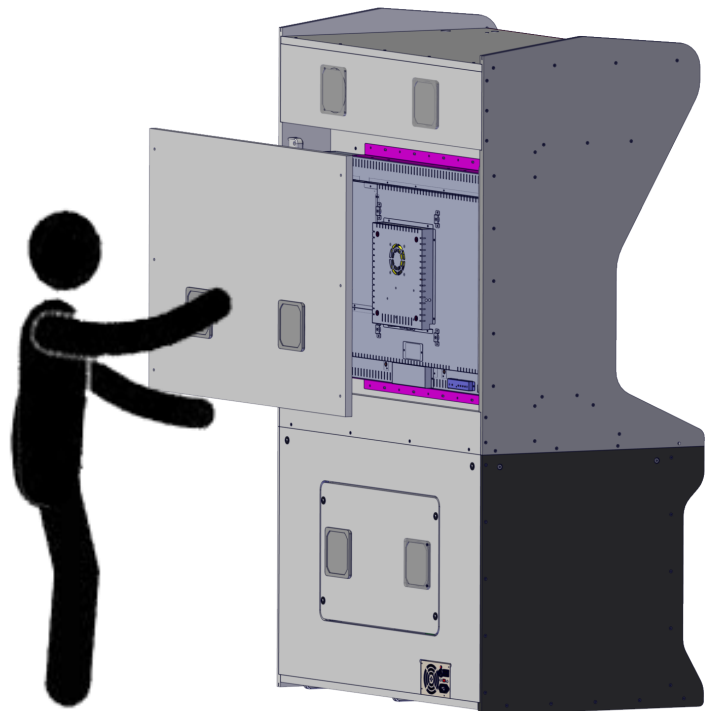
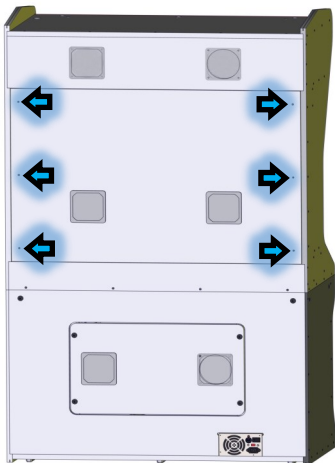

Install one AA6281 Allen bolt and AA6212 washer at each side of the backside of the cabinet. See circle diagrams for locations.

Make sure the alignment of the side panels of the cabinet are straight, then tighten the two at front and two at back mounting bolts.

Locate the DVI and AC Power cord at the bottom of the cabinet. Attach the video DVI cable to VIDEO DVI and the AC power cord to AC IN on the monitor.

Then connect the upper cabinet harness shown below.

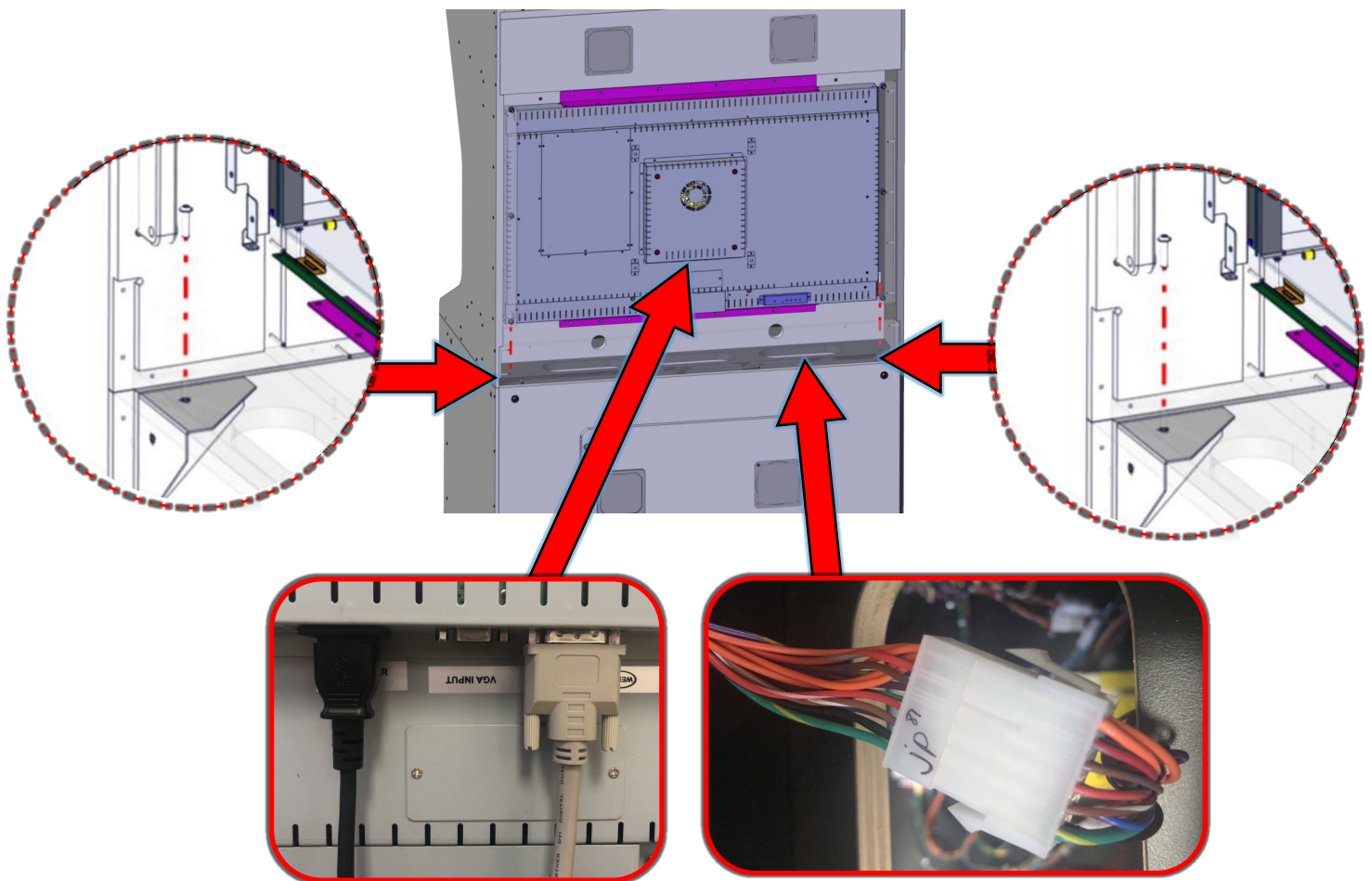

Re-install the back door panel. Use AA6220 bolts and AA6212 washers you removed previously.

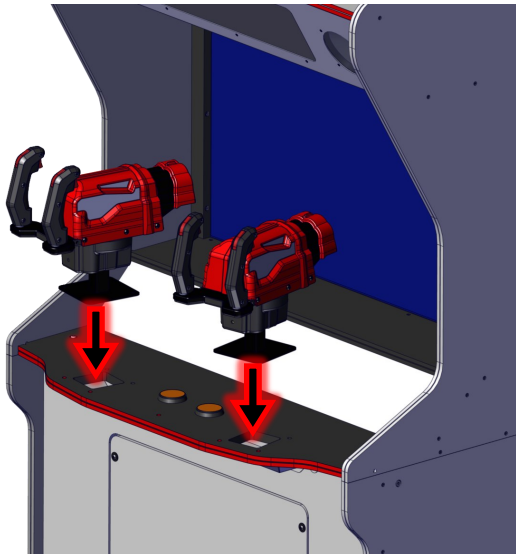

Unpack the two gun assemblies. Insert the gun assembly into the gun mounts on the control panel.

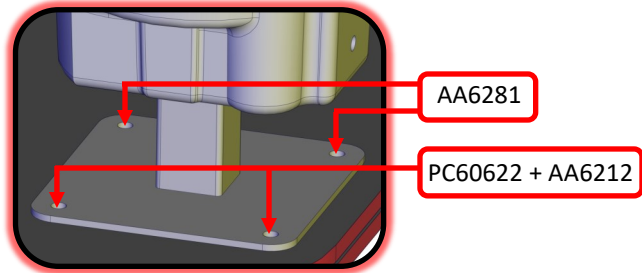
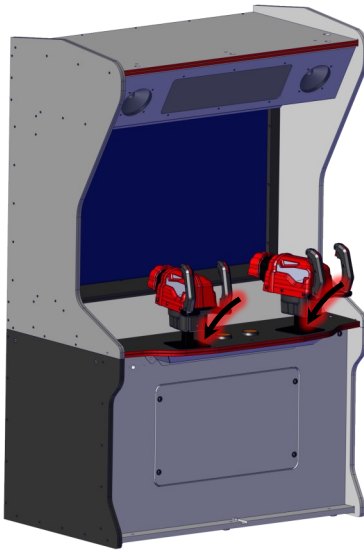

Use PC60622 Allen bolts at the rear and AA6281 Allen bolts with AA6212 washers at the front. Secure the front Allen's with PC60604 nylon nuts.

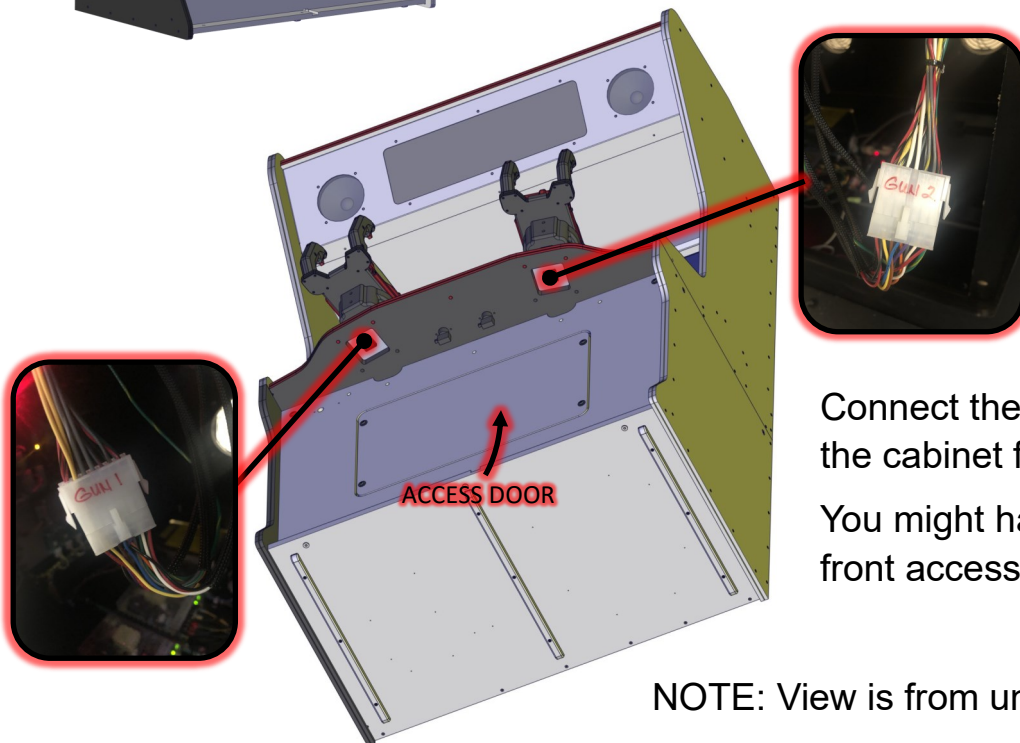

Connect the gun harnesses to the cabinet from underneath. You might have to remove the front access door to find them.

NOTE: View is from underneath cabinet.

Attach the gun harness cover using five PC60622 Allen bolts.

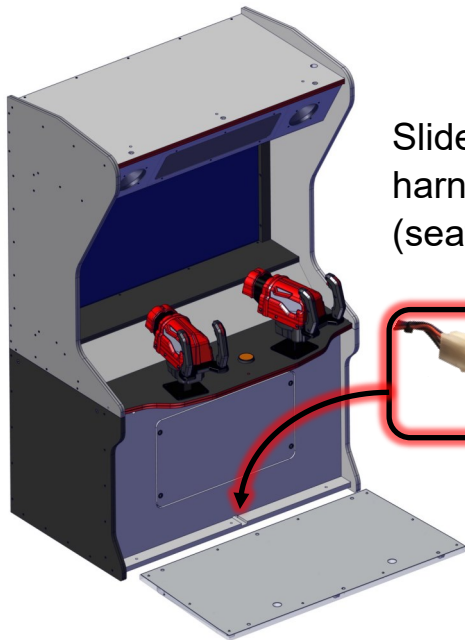
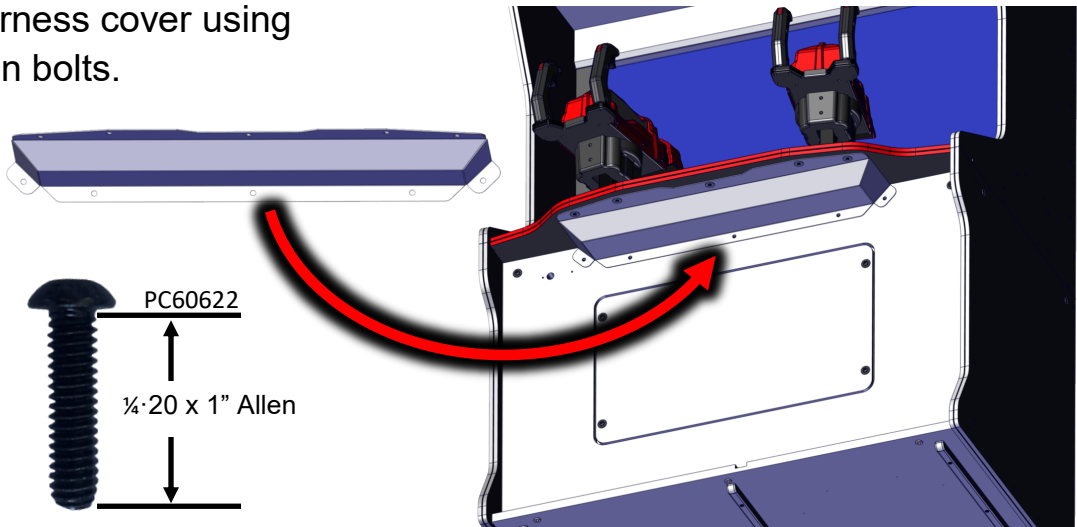

Slide the floor assembly to the front and attach the harness shown. The two holes go toward the back (seat) of the cabinet.

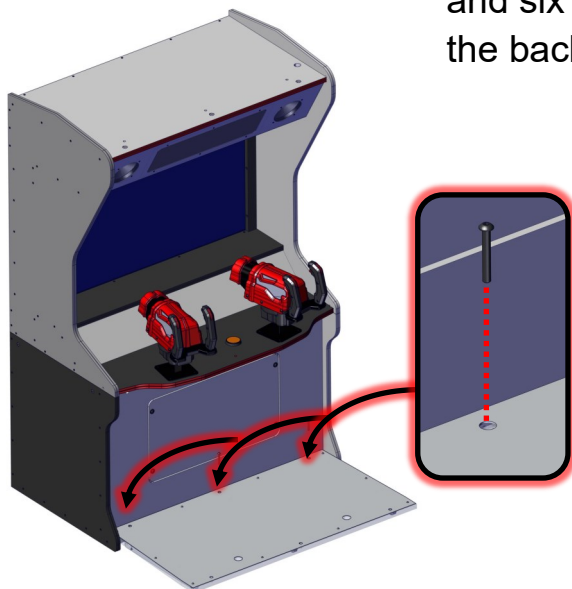

Secure the front half using six AA6220 Allen bolts and six AA6212 washers but do not fully tighten until the back half is installed.



Attach the back harness to the seat assembly.

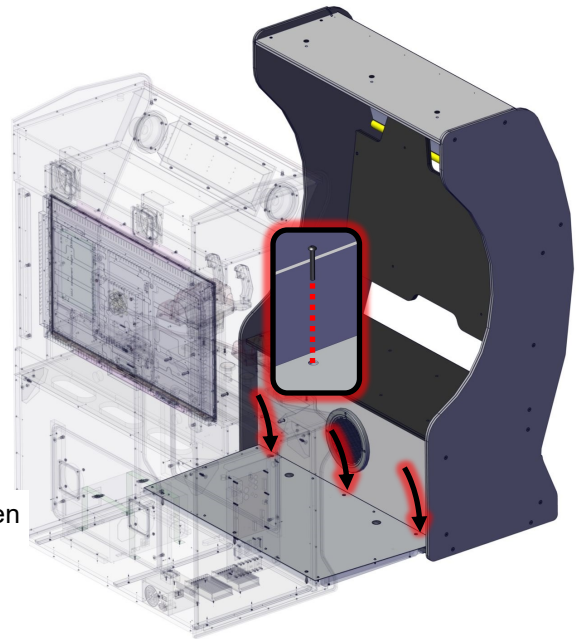
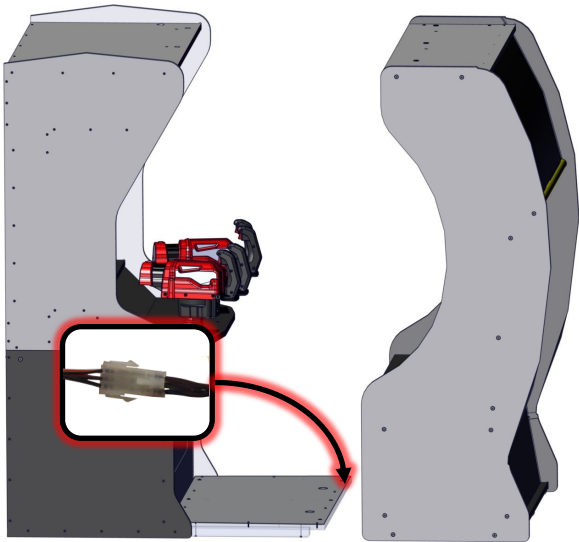

Secure using AA6211 but do not fully tighten until all bolts are started. Then secure all bolts on floor.

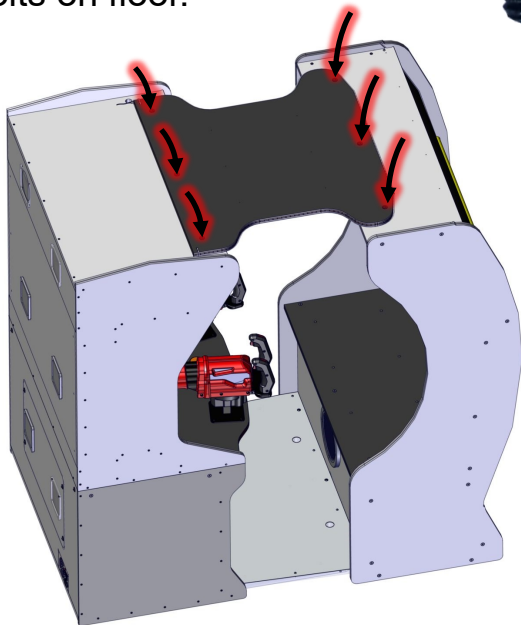
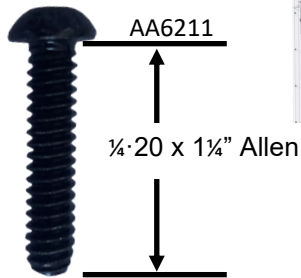

Secure the roof using six AA6220 Allen bolts and six AA6212 washers.



Secure the Dino sign using two AA6211 Allen bolts and two AA6212 washers.



# Rear Seat Assembly (If disassembled).

**3X's**



AA6744  
1/4-20 X 5/8  
DOWEL NUT  
SILVER ZINC

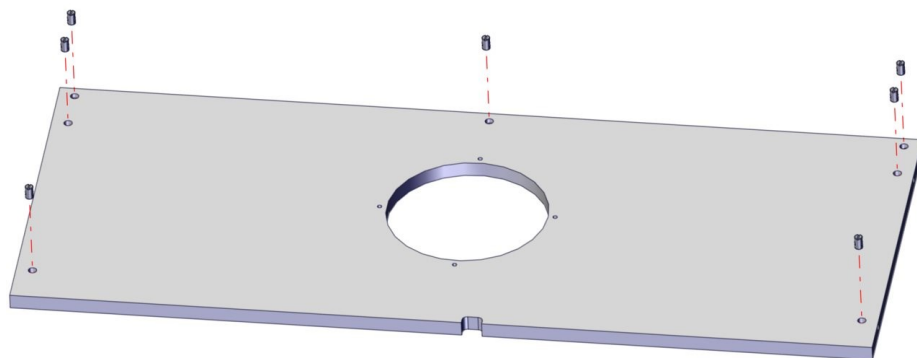

**3X's**



AA6318  
1/4-20 X 1-9/16  
BLACK ZINC

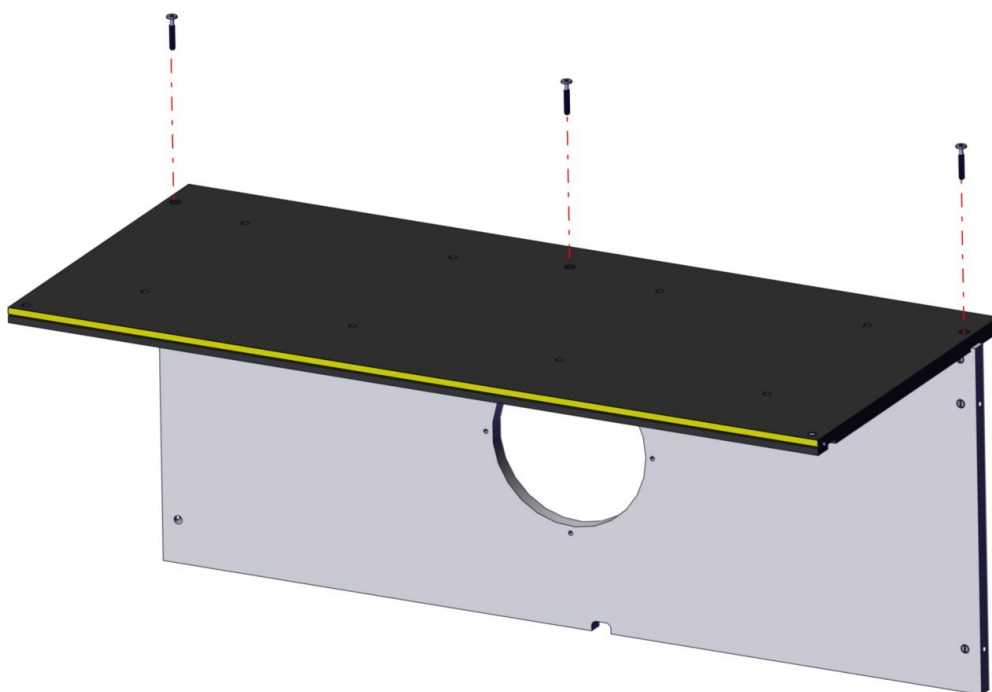

**2X's**



AA6744  
1/4-20 X 5/8  
DOWEL NUT  
SILVER ZINC

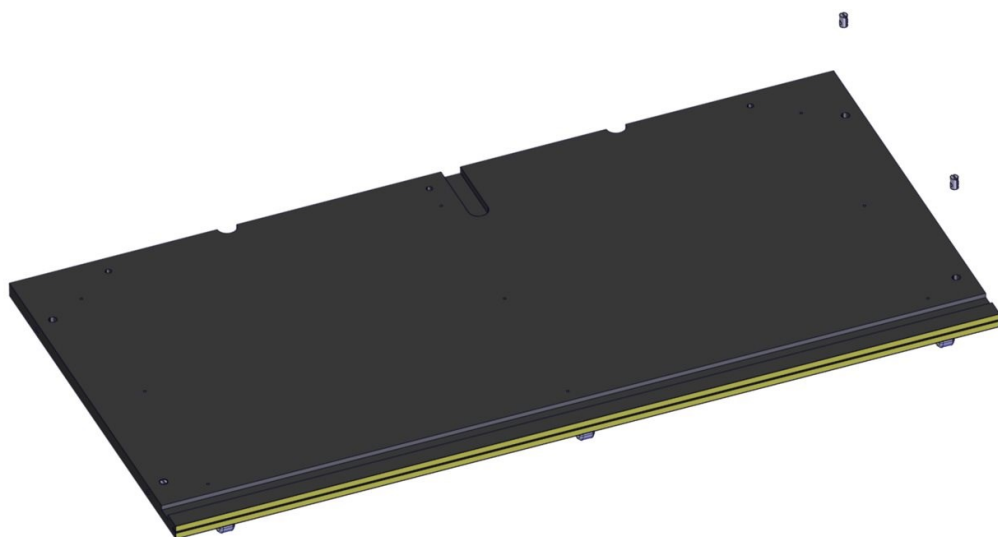



**5X's**  
AA6318  
1/4-20 X 1-9/16  
BLACK ZINC

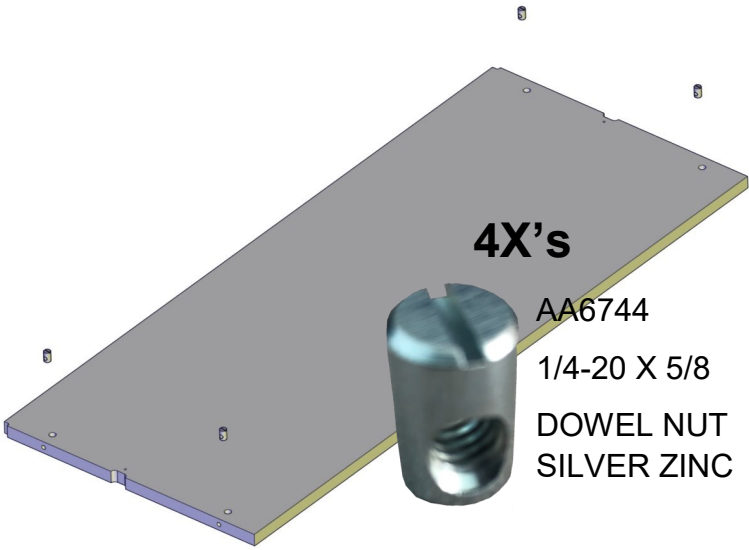
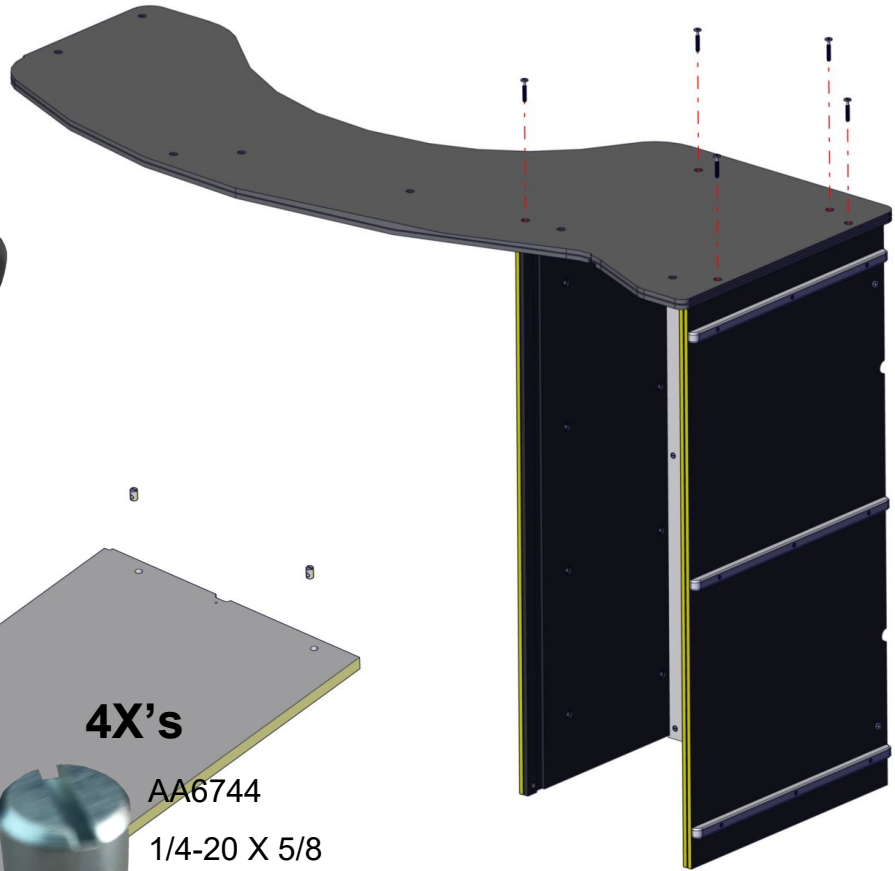

AA6744  
1/4-20 X 5/8  
DOWEL NUT  
SILVER ZINC

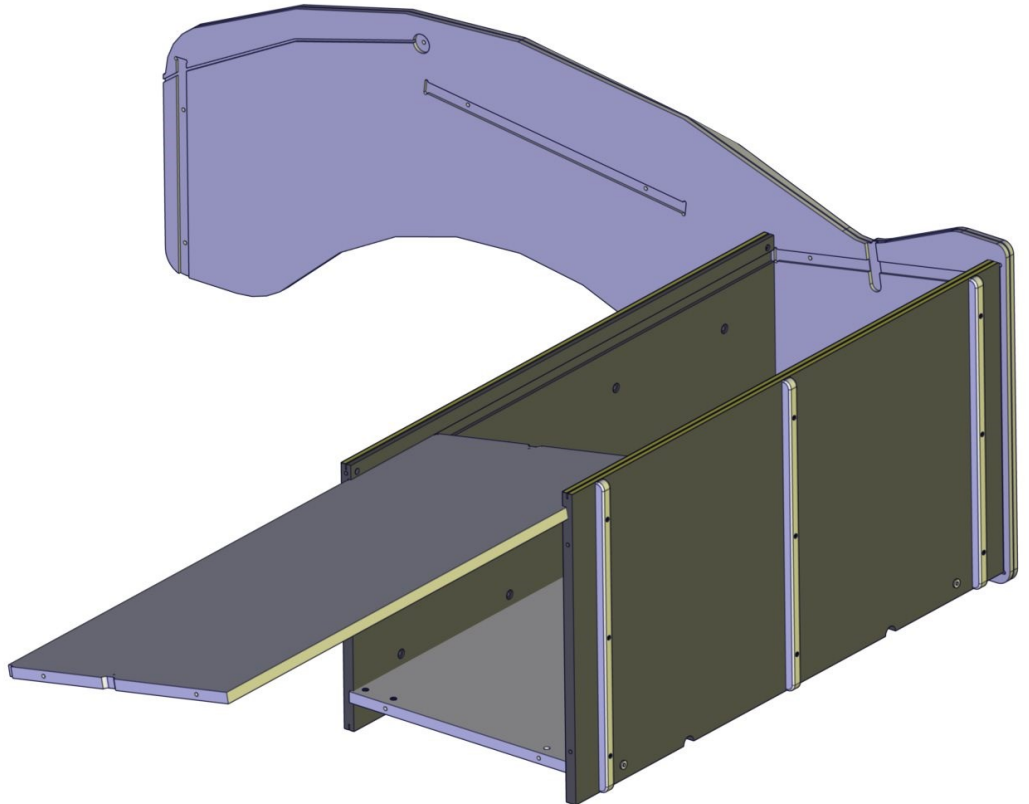

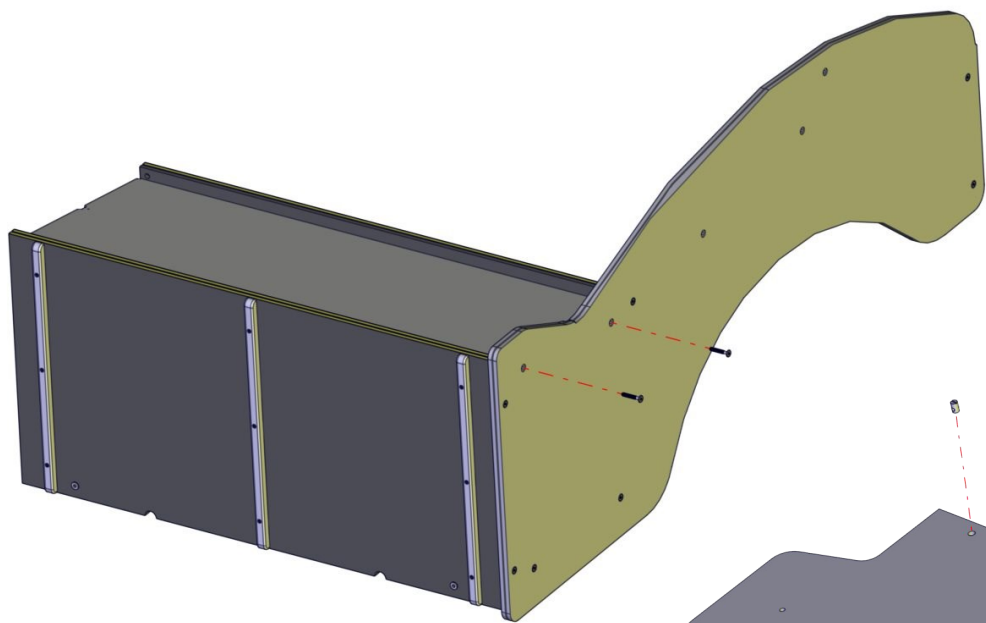

**2X's**



AA6318  
1/4-20 X 1-9/16  
BLACK ZINC

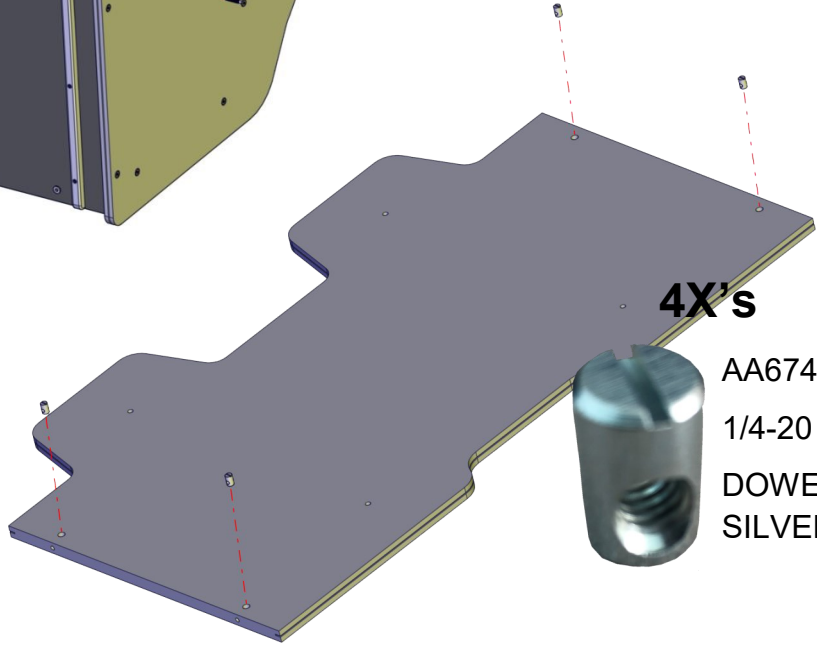

**4X's**



AA6744  
1/4-20 X 5/8  
DOWEL NUT  
SILVER ZINC

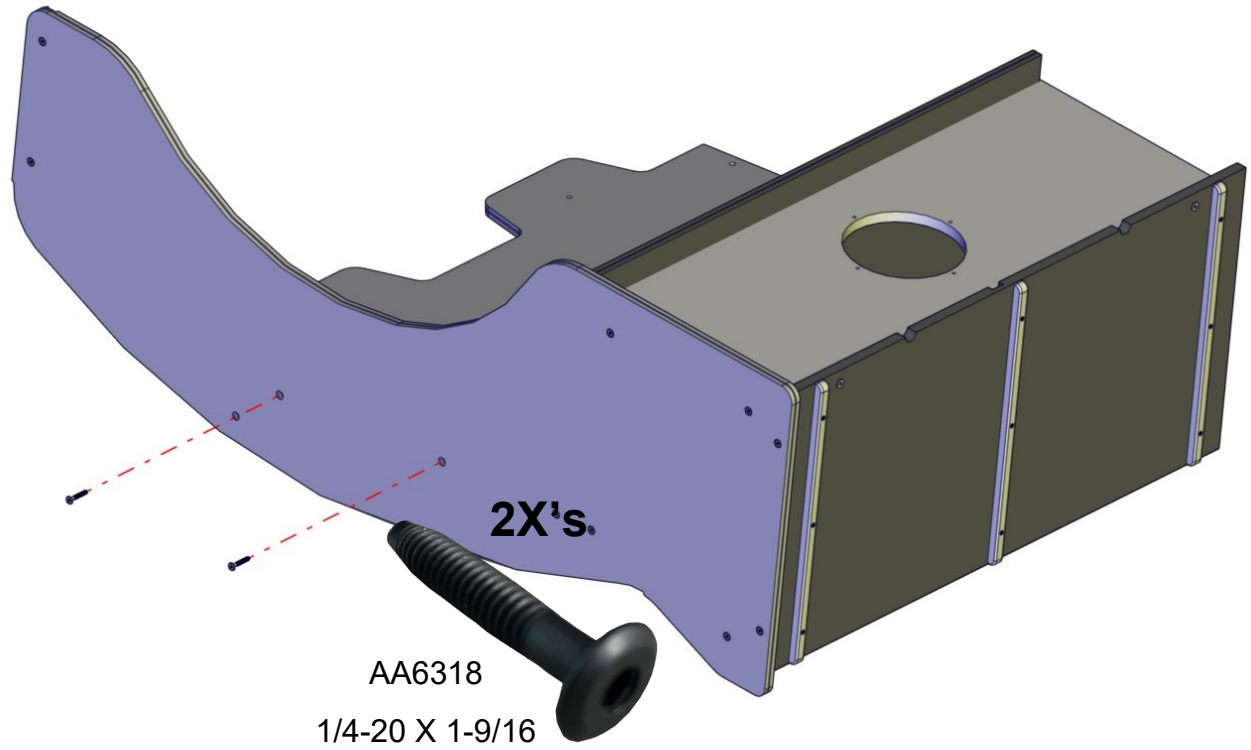

**2X's**



AA6318  
1/4-20 X 1-9/16  
BLACK ZINC

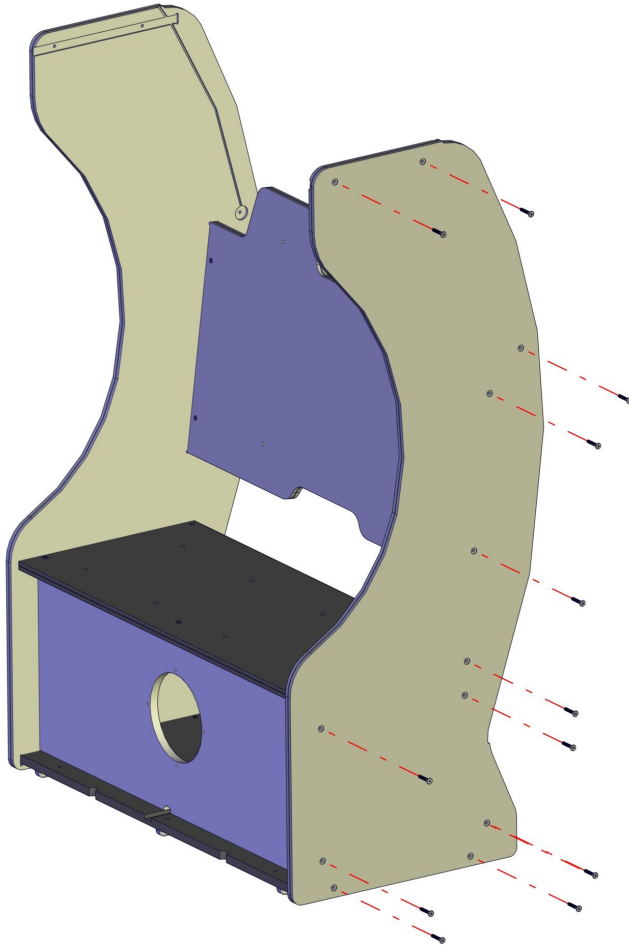

**12X's**



AA6318  
1/4-20 X 1-9/16  
BLACK ZINC



**2X's**

AA6318  
1/4-20 X 1-9/16  
BLACK ZINC

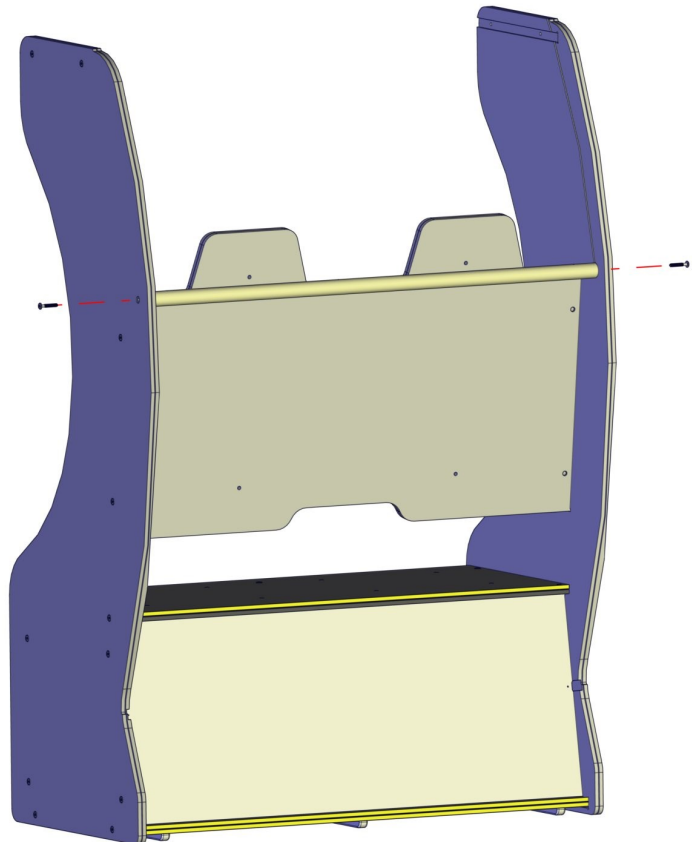

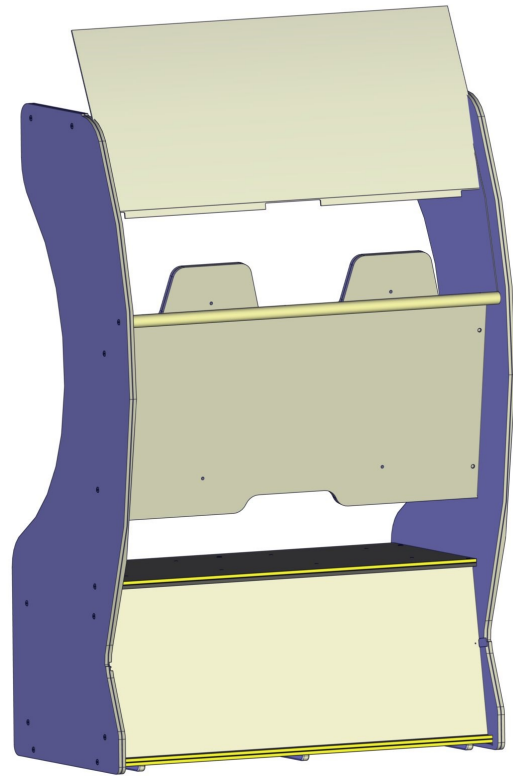

**4X's**



AA6744  
1/4-20 X 5/8  
DOWEL NUT  
SILVER ZINC

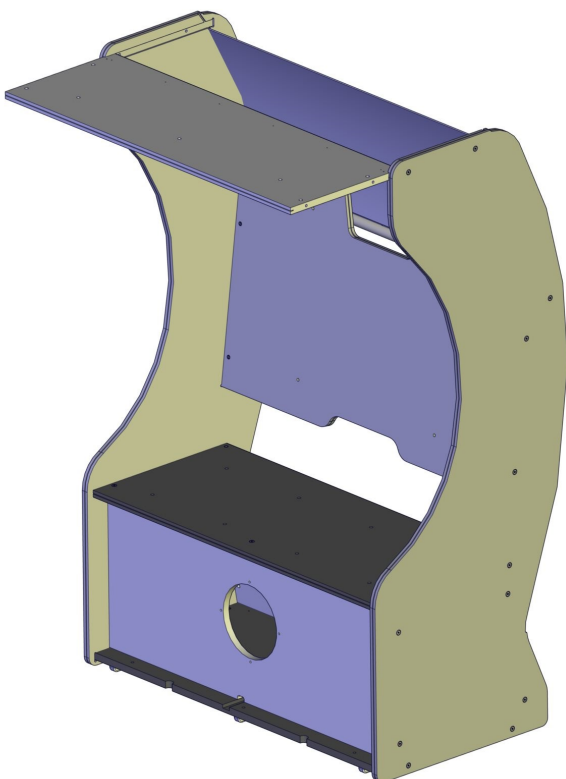

**4X's**

AA6318  
1/4-20 X 1-9/16  
BLACK ZINC

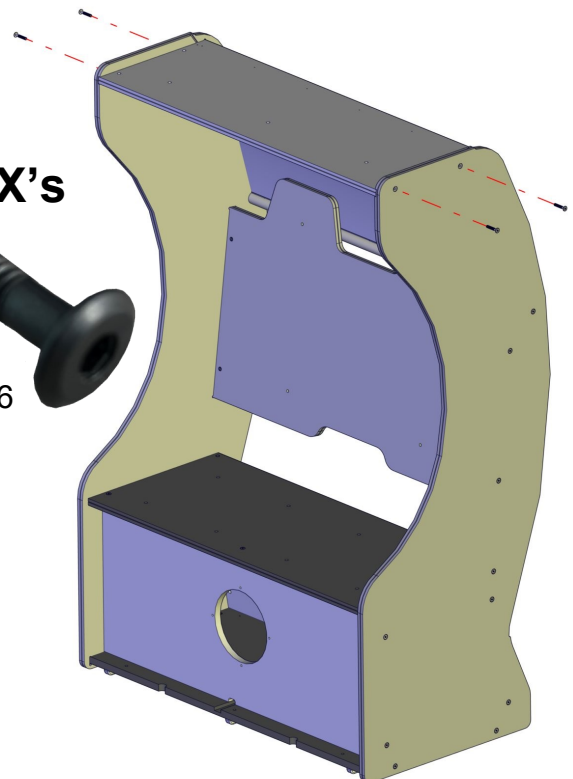

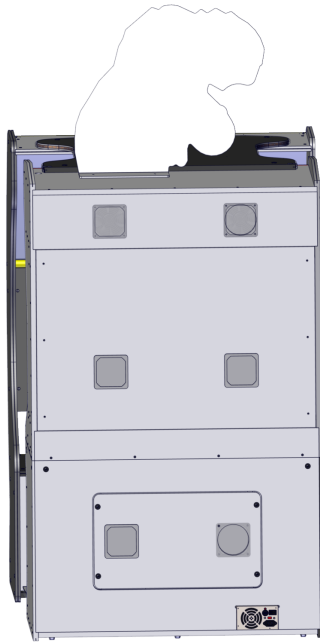

## AC Power plug

You will need to plug in the AC power cord once you have the game setup. The AC cord plugs into the power supply located at the rear of the game and at the bottom.

Make sure the AC power switch is set to - and not o.



Switch must be on “-”

AC CORD GOES HERE

## How to Enter Programming

In the attract mode (not in game mode) press and hold the PWR button for 3 seconds to enter the program options.

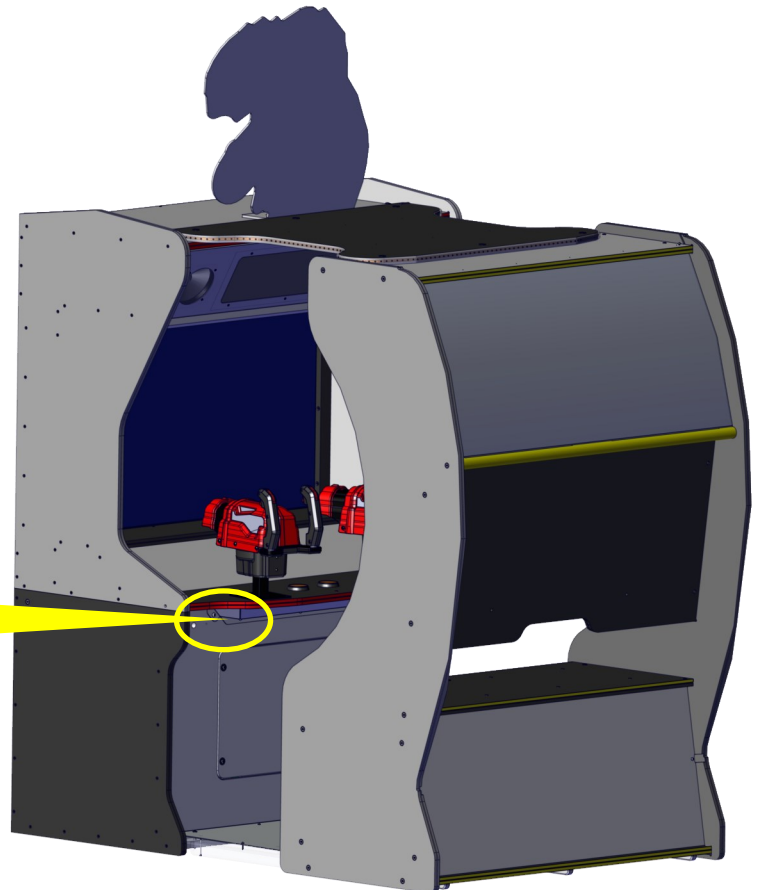

## Navigating the menu and changing values

Press the “STEP +” and “TEST -” buttons to scroll through the menus.

Press the “SEL” button to enter the desired menu.

Press the “STEP +” and “TEST -” buttons to change the option selected.

Press the “PWR” button to save any changes.

## Menu Screens and Descriptions

### Main Menu

- **Diagnostics** - verify game inputs and outputs are functional
- **Pricing** - view various tracking statistics
- **Game Adj** - setup and manage game parameters
- **System Adj** - setup and manage system parameters
- **Audits** - view various hardware and software information ie. collection and play data
- **Gun Cal** - calibrate and verify gun functionality
- **Game Vol** - adjust game and attract volume

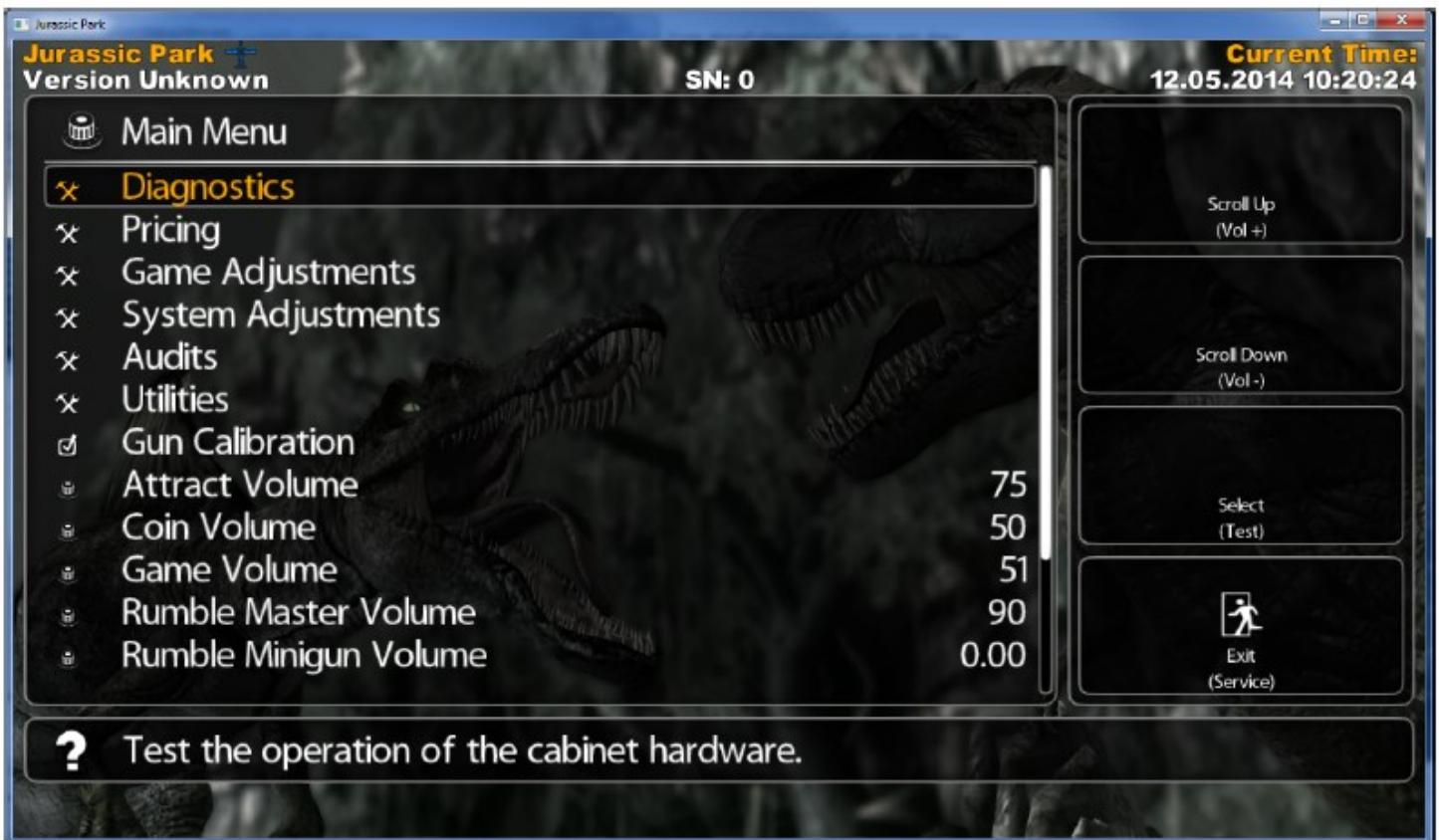

## Main Menu

### Game Adjustments

Adjust in-game parameters. Customize in-game features to suit customer base and location.



## Main Menu

### Gun Calibration

Maximize your games earning potential by making sure that the guns are periodically calibrated and all switch inputs are functional.







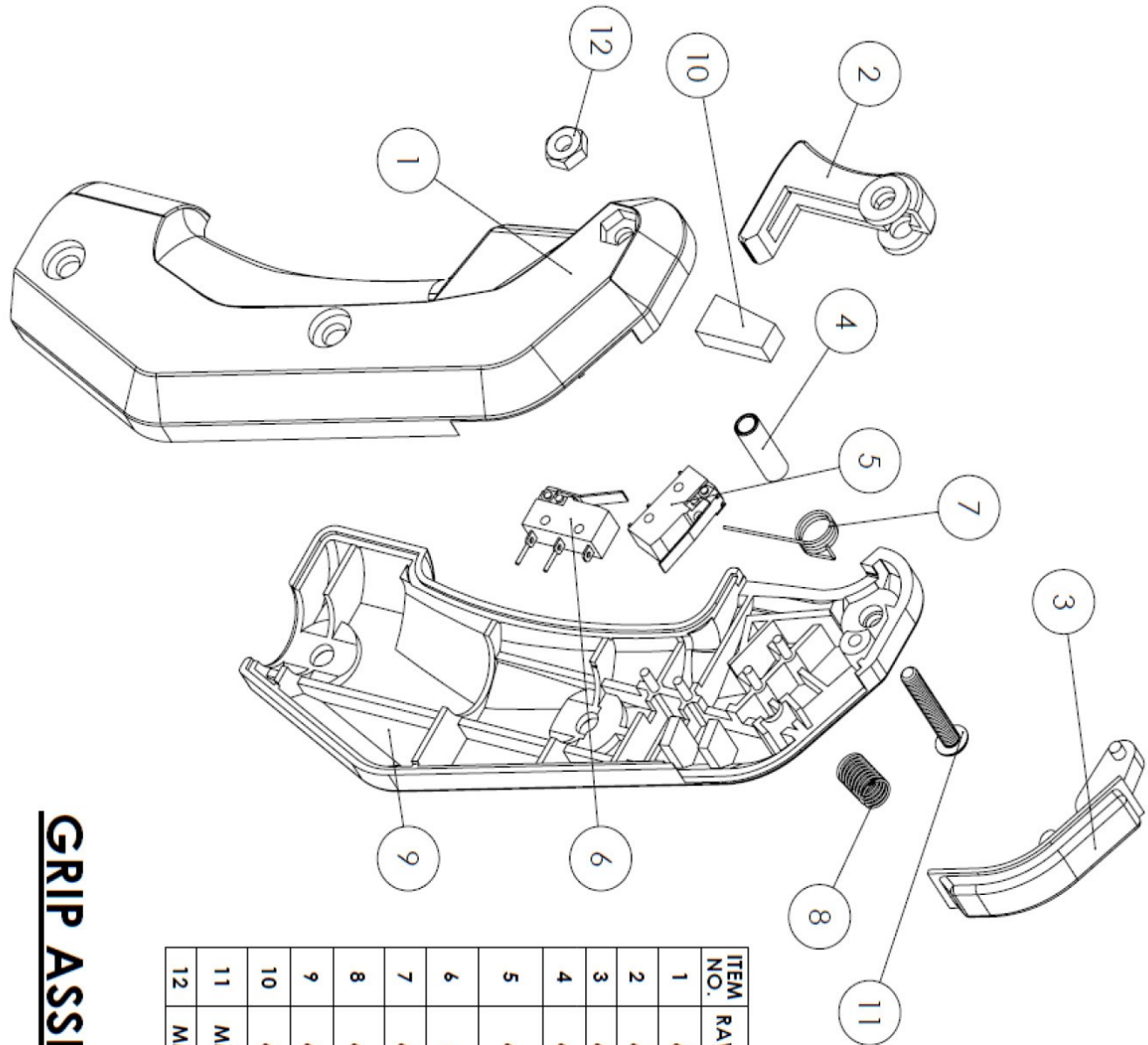

ITEM NO.	RAW PART NUMBER	HAPP NUMBER	DESCRIPTION	QTY.
1	608-00201-01	95-1294-00	GRIP, LEFT HALF	1
2	608-00204-01	95-1295-00	TRIGGER, RED	1
3	608-00203-01	95-1439-00	LARGE THUMB BUTTON	1
4	608-00205-01	95-1315-00	SHAFT, TRIGGER	1
5	608-00216-01	95-0259-00	SWITCH ASSY FOR THUMB SWITCH	1
6	608-00215-01	95-0028-00	SWITCH ASSY. FOR TRIGGER	1
7	608-00206-01	95-1297-00	SPRING, TORSION	1
8	608-00207-01	95-1298-00	SPRING, COMPRESSION	1
9	608-00202-01	95-1293-00	GRIP, RIGHT HALF	1
10	608-00218-01	96-0110-00	TRIGGER BUMPER	1
11	MMC 96075A147	43-0378-00	SCREW, #8-32 x 1 TP BLACK	1
12	MMC 86537A140	43-1124-00	HEX NUT #8-32 BLACK	1

# GRIP ASSEMBLY

REV.	DESCRIPTION	DATE
A	RELEASED	11/17/10

RAW THRILLS INC.	
GRIP ASSEMBLY	
TITLE	DATE
DESIGNED BY	REVISED BY
CHECKED BY	DATE
APPROVED BY	DATE
PAGE NO.	TOTAL PAGES
1	1

REV.	DESCRIPTION	DATE
A	RELEASED	10/18/14
B	REVISED	1/9/15

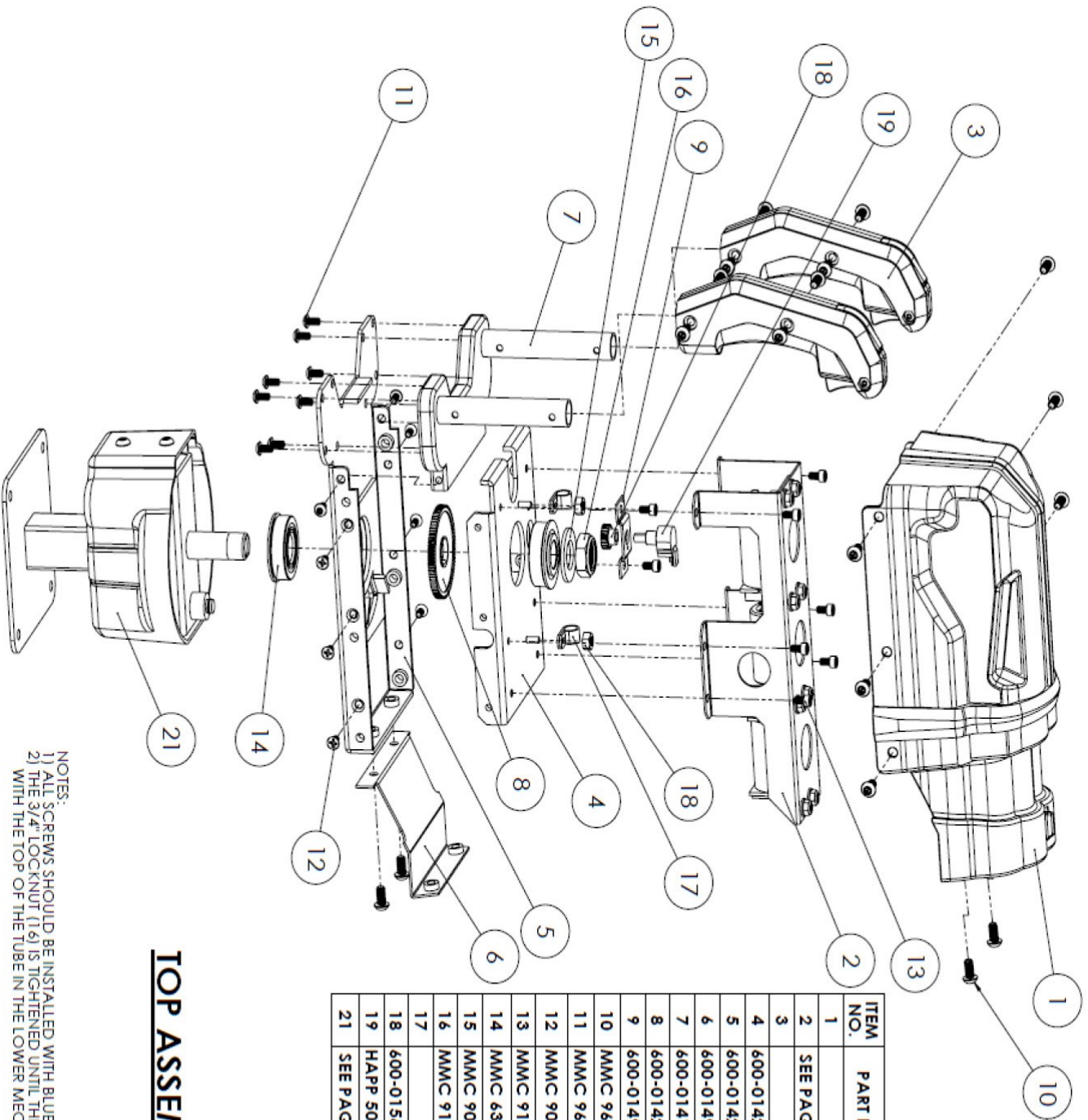

ITEM NO.	PART NUMBER	DESCRIPTION	QTY.
1	SEE PAGE 3	UPPER VACFORM ASSEMBLY	1
2	SEE PAGE 3	SHAKER ASSEMBLY	1
3	600-01422-01	GRIP ASSEMBLY	2
4	600-01423-01	PIN PLATE	1
5	600-01423-01	COVER BRACKET	1
6	600-01495-01	FRONT VACFORM BRACKET	1
7	600-01411-01	GRIP PLATE WELDMENT	1
8	600-01420-01	LARGE GEAR	1
9	600-01491-01	POT BRACKET	1
10	MMC 96075A211	1/4-20 X 1/2" BLK TP SCREW	18
11	MMC 96075A183	10-32 X 3/8" BLK TP SCREW	10
12	MMC 90273A827	10-32 X 3/8" FLAT HEAD SCREW	6
13	MMC 91251A337	10-32 X 5/16" CAP SCREW	8
14	MMC 6384K369	3/4" FLANGED BEARING	2
15	MMC 90126A036	3/4" WASHER	1
16	MMC 91342A240	3/4" LOCKNUT	1
17	600-01567-01	CABLE CLAMP	2
18	600-01567-01	SMALL POT GEAR	1
19	HAPP 50-2670-01	POT - 5K	1
21	SEE PAGE 2	LOWER MECH ASSEMBLY	1

## TOP ASSEMBLY

NOTES:  
 1) ALL SCREWS SHOULD BE INSTALLED WITH BLUE LOCTITE 242 or 243.  
 2) THE 3/4" LOC KNUT (16) IS TIGHTENED UNTIL THE TOP IS FLUSH WITH THE TOP OF THE TUBE IN THE LOWER MECH ASSEMBLY (21).

RAW THRILLS INC.	
JOB NO. 1000	
DATE: 10/18/14	REV: B
PART 1 OF 1	



# WARRANTY POLICY

I.C.E. Inc warrants all components in your new Jurassic Park Home Edition machine to be free of defects in materials and workmanship for the period of **ONE YEAR** from purchase date.

I.C.E. Inc shall not be obligated to furnish a warranty request under the following conditions:

- The game is operated commercially.
- Equipment has been subjected to unwarranted stress, abuse or neglect.
- Equipment has been damaged as a result of arbitrary repair/modification.

Products will only be covered under warranty free of charge by obtaining an I.C.E. authorized RMA #. To obtain an RMA # please provide I.C.E. tech support with the game serial # or original I.C.E. invoice # and a detailed description of the failure or fault symptoms.

I.C.E. Inc will assume no liability whatsoever for costs associated with labor or travel time to replace defective parts. All defective warranty covered components will be replaced with new or factory refurbished components equal to OEM specifications.

I.C.E. Inc will cover domestic UPS ground, or comparable shipping costs during the warranty period. International or expedited shipments are available for an additional charge.

ICE distributors are independent, privately owned and operated. In their judgment, they may sell parts and/or accessories other than those manufactured by I.C.E. Inc. We cannot be responsible for the quality, suitability or safety of any non-I.C.E. part or modification (including labor) that is performed by such a distributor.

Innovative Concepts in Entertainment  
**10123 Main St.**

**Clarence, NY 14031**

**Phone #: (716) - 759 – 0360**

**Fax #: (716) – 759 – 0884**

[www.icegame.com](http://www.icegame.com)