

Assembly Guide & User Manual



Table of Contents

Safety....Before you begin	3
Parts Included	4
Before you begin assembly	5
Cabinet Assembly	6
Game Modes	17
Game Options.	18
Access to Electronics	19
Score Sensor	20
Main board Connections	21
Warranty Policy	22

SAFETY BEFORE YOU BEGIN

WHEN INSTALLING THIS GAME, A GROUNDED A.C. RECEPTACLE MUST BE USED. FAILURE TO DO SO COULD RESULT IN INJURY TO YOURSELF OR OTHERS. FAILURE TO USE A GROUNDED RECEPTACLE COULD ALSO CAUSE IMPROPER GAME OPERATION, OR DAMAGE TO THE ELECTRONICS. THIS GAME IS DESIGNED TO DISSIPATE STATIC ELECTRICITY THROUGH THE GROUNDING PLANE OF THE GAME. IF THE A.C. GROUND DOES NOT WORK, THE GAME COULD DISCHARGE STATIC ELECTRICITY THROUGH THE GAME CIRCUITRY, WHICH COULD CAUSE DAMAGE.

DO NOT DEFEAT OR REMOVE THE GROUNDING PRONG ON THE POWER CORD FOR THE SAME REASON AS GIVEN ABOVE. USING AN IMPROPERLY GROUNDED GAME COULD VOID YOUR WARRANTY.

IF YOU HAVE ANY QUESTIONS ABOUT YOUR OUTLET HAVE QUALIFIED ELECTRICIAN CHECK YOUR A.C. RECEPTACLE TO BE SURE THE GROUND IS FUNCTIONING PROPERLY.

THE POWER SUPPLY IS NOT VOLTAGE ADJUSTABLE. TO OPERATE THE GAME AT VOLTAGES OTHER THAN THOSE IT WAS DESIGNED FOR. PLEASE CONTACT OUR SERVICE DEPARTMENT FOR VOLTAGE CONVERSION INFORMATION.

DO NOT remove any of the components on the main board while the game is powered on. This may cause permanent damage to the parts and the main board. Doing so will void the warranty of your game.

ALWAYS REMOVE POWER TO THE GAME, BEFORE ATTEMPTING ANY SERVICE, UNLESS NEEDED FOR SPECIFIC TESTING.

FAILURE TO OBSERVE THIS PRECAUTION COULD RESULT IN SERIOUS INJURY TO YOURSELF OR OTHERS.

NOTE: THIS GAME IS INTENDED FOR INDOOR USE ONLY.

THIS GAME IS NOT SUITABLE FOR OUTDOOR USE OR WET ENVIROMENTS OR IN AREAS WHERE A WATER JET COULD BE USED.

This game is not intended for use by persons (including children) with reduced physical, sensory or mental capabilities, or lack of experience and knowledge, unless they have been given supervision or instruction concerning use of this game by a person responsible for their safety. Children should always be supervised when playing this game.

The game's foot print is Depth 95.3125" x width 39.1875" (43 with graphic floor).

WE RECOMMEND AT LEAST TWO ADULTS TO ASSEMBLY THIS GAME.

Watch the video on how to assembly at "<https://www.youtube.com/watch?v=miQoUFGRBhQ> "

AC Power Information

The games main fuse is accessed **at the side of the backboard, at the back.**

Above the power cord is a small panel that contains the main fuse.

The value of the fuse for 120 volt users is 2.5 AMPS at 250Volt type slow blow.



Parts Included

Before you begin to assemble your game locate the parts below.

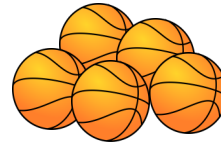
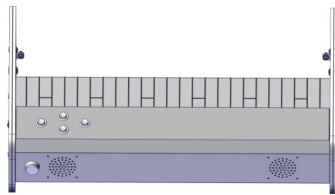
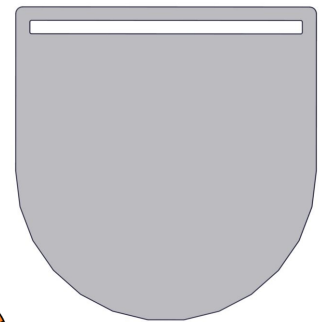
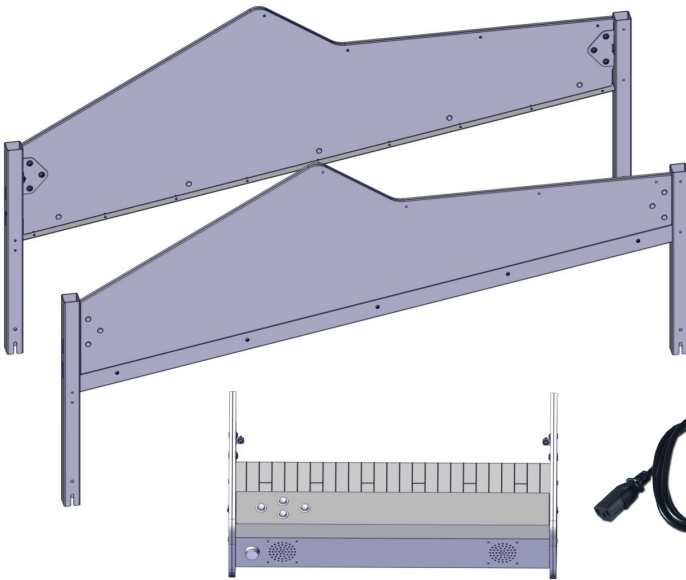
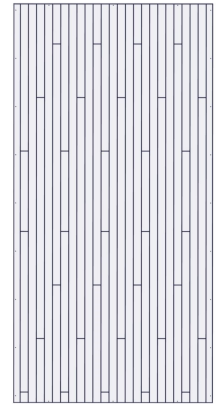
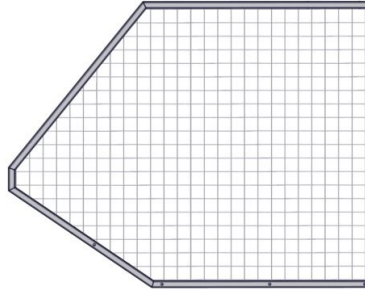
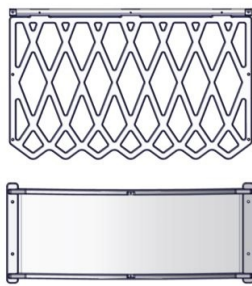
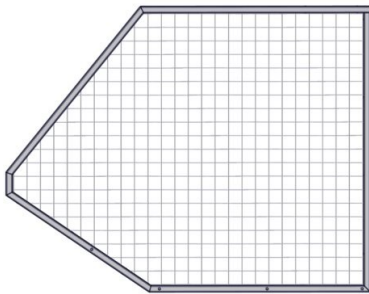
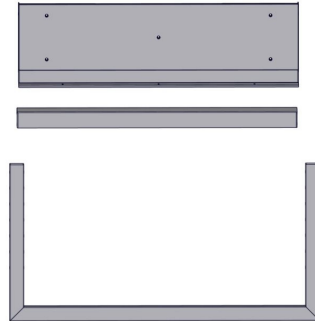
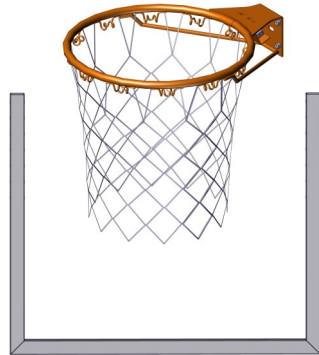
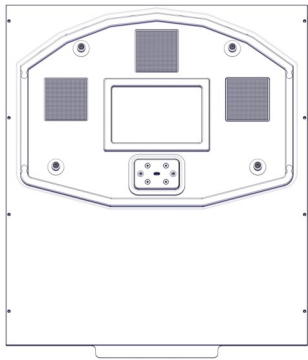

If any parts are missing please contact ICE Service at (716) 759-0360 Monday through Friday 8:30 am to 6 pm Eastern Standard.



BEFORE YOU BEGIN ASSEMBLY

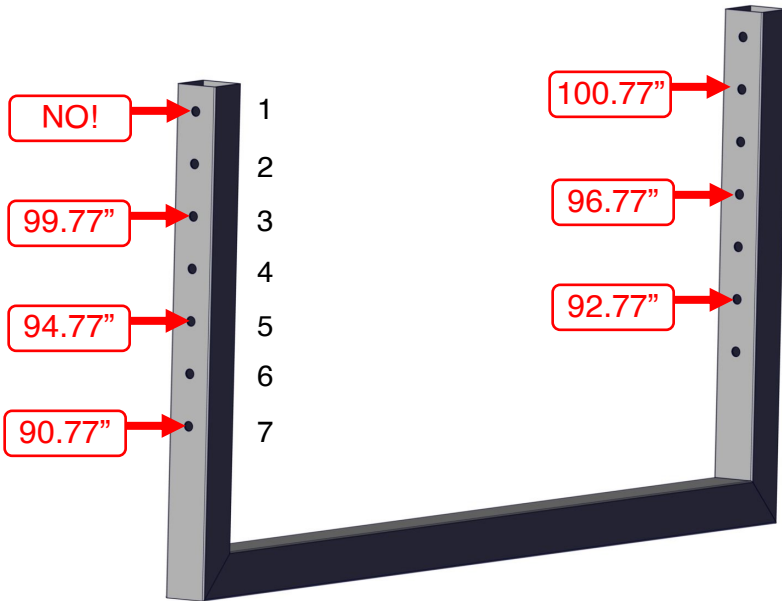

Before you begin, determine what height you will assembly your game to.

Both leg assemblies have seven holes. The measurements provided are for a completely assembled game.

If the upper roof assembly is not installed, you can subtract 4" from these measurements.

The top hole cannot be used for height determination. Two holes are required when mounting the legs to the base.

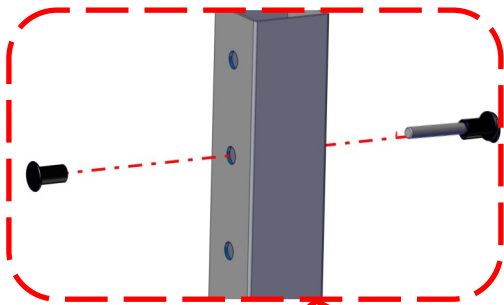

Once you determine your desired height of the game, use the correct hole. Insert one AA6110 nut into one side and AA6107 shaft plus AA6110 nut to the other side. Do not tighten. There must be a gap on both sides. Repeat for all legs.

LEGS

(8) AA6110 Inserts

(4) AA6107 bolts

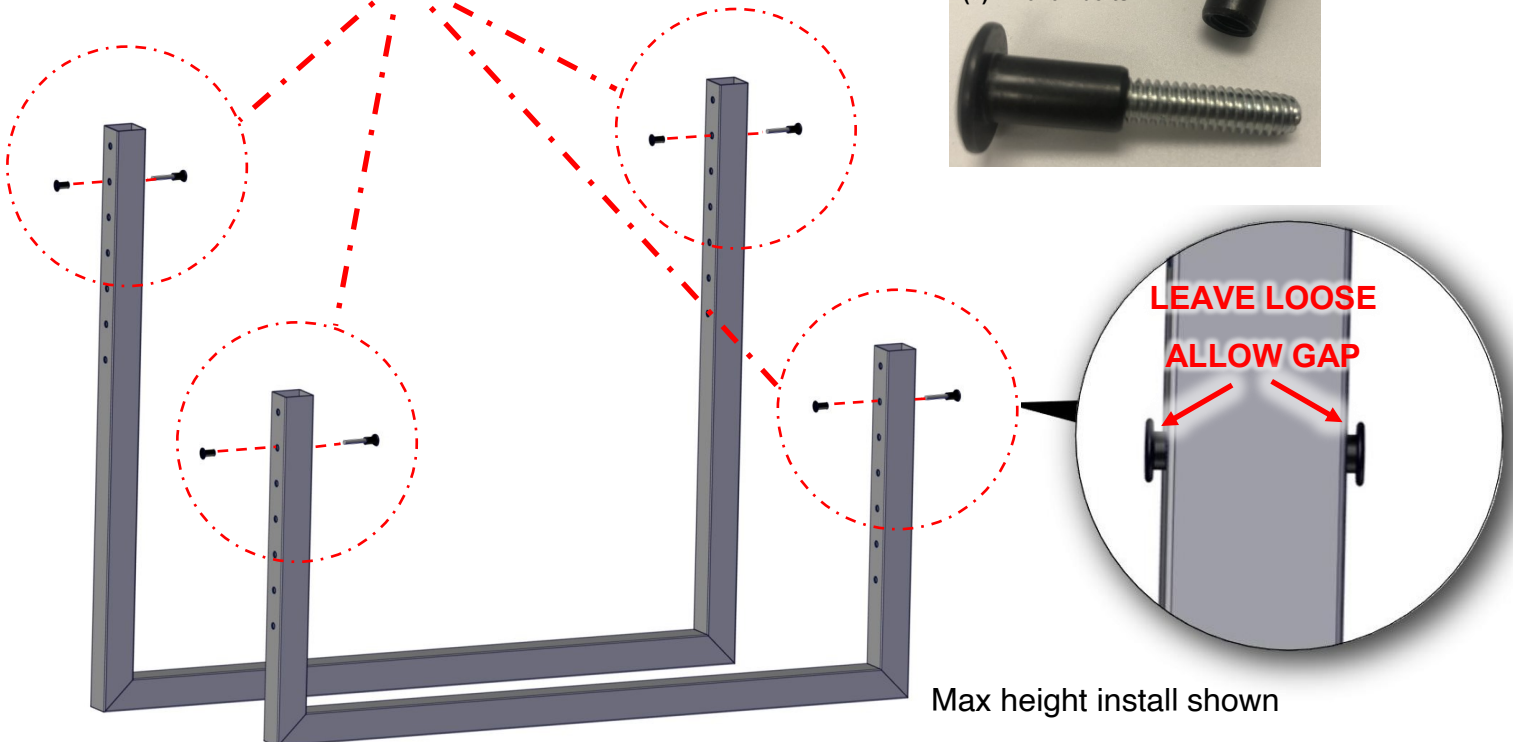

Max height install shown

CABINET ASSEMBLY

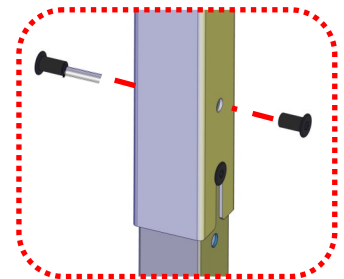
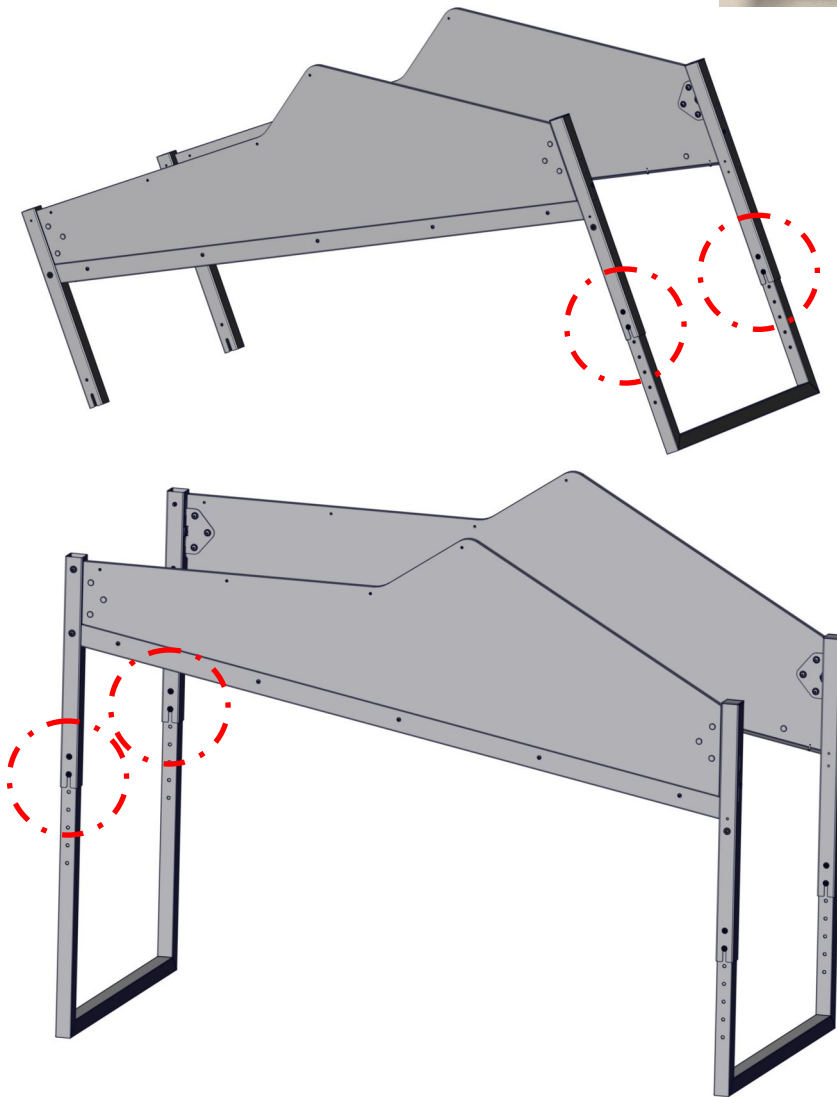

Insert LEG hardware to secure legs.
Tighten using supplied tools.

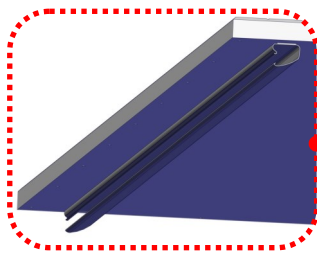

Lay plywood panel down with wire harness channel to the left.

Insert bolts and washers at the top and nuts at the bottom.

Green ground wire attaches to the back left bolt UNDERNEATH cabinet.

NOT ON TOP!!

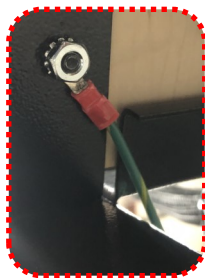
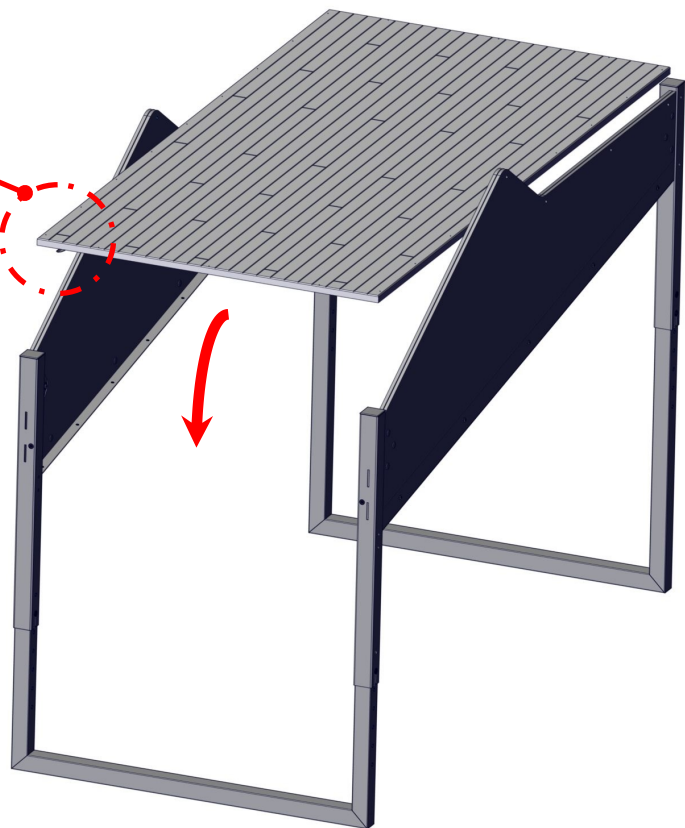

Floor

(10) AA6953 Bolt

(10) AA6288 Washer

(10) AA6004 Nut

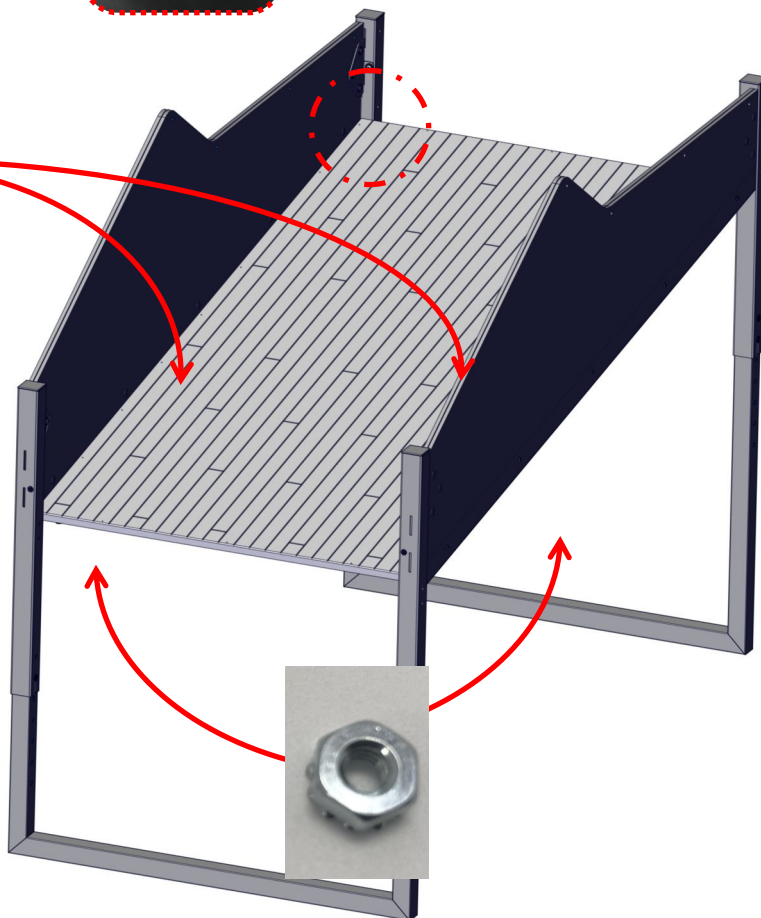

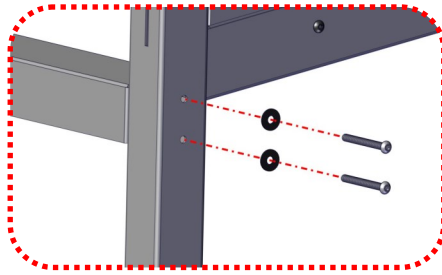
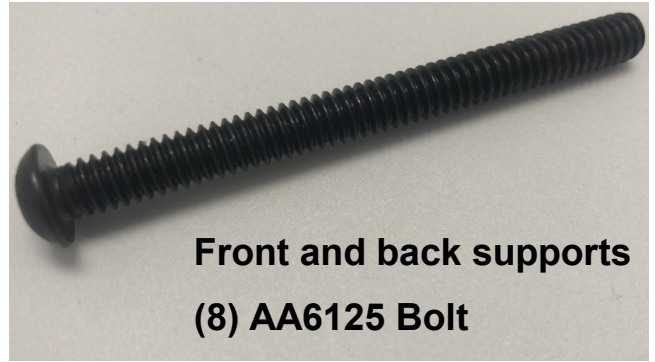
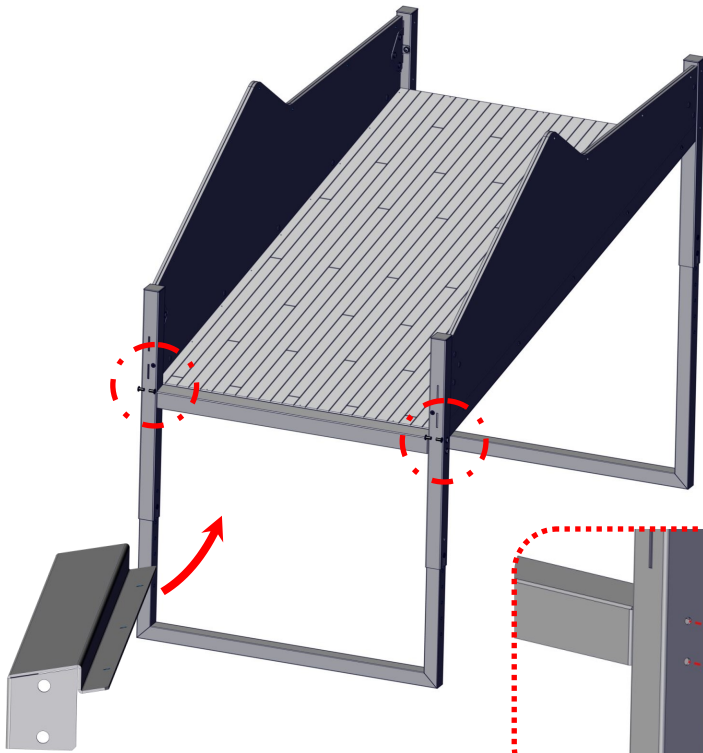

Attach the front and back supports.

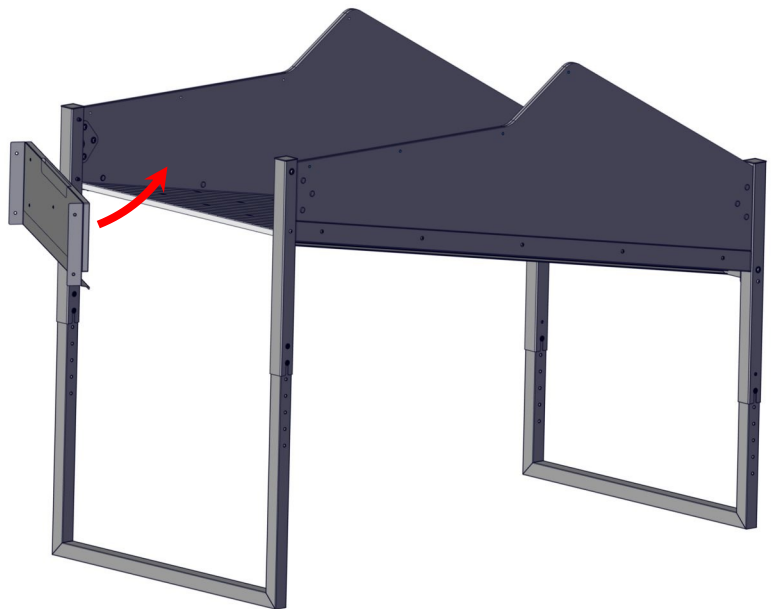
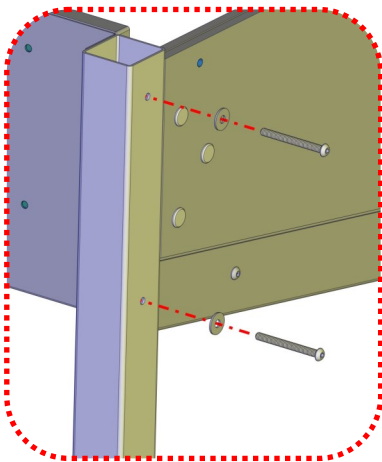

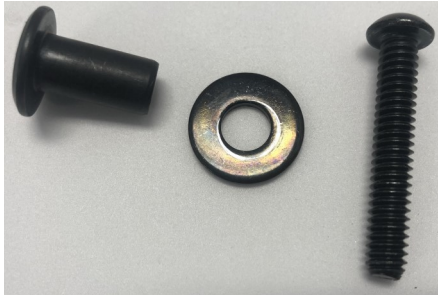

Cage Sides

(8) AA6281 Bolt

(8) AA6212 Washer

(8) AA6110 Insert

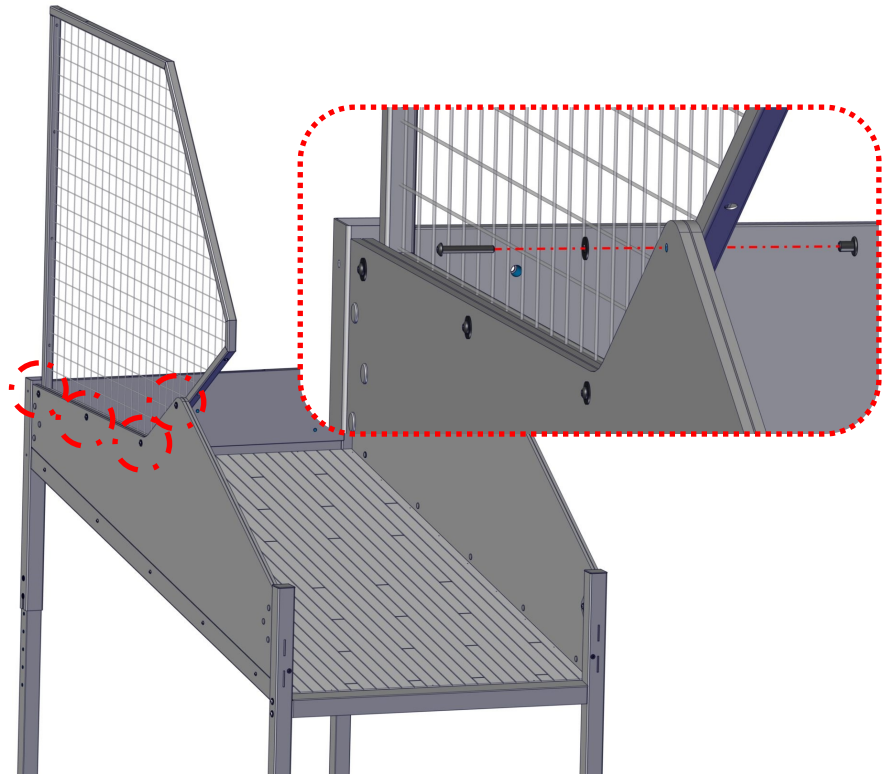

AA6281 bolts and AA6212 washers to the outside.

AA6110 inserts go on the inside.

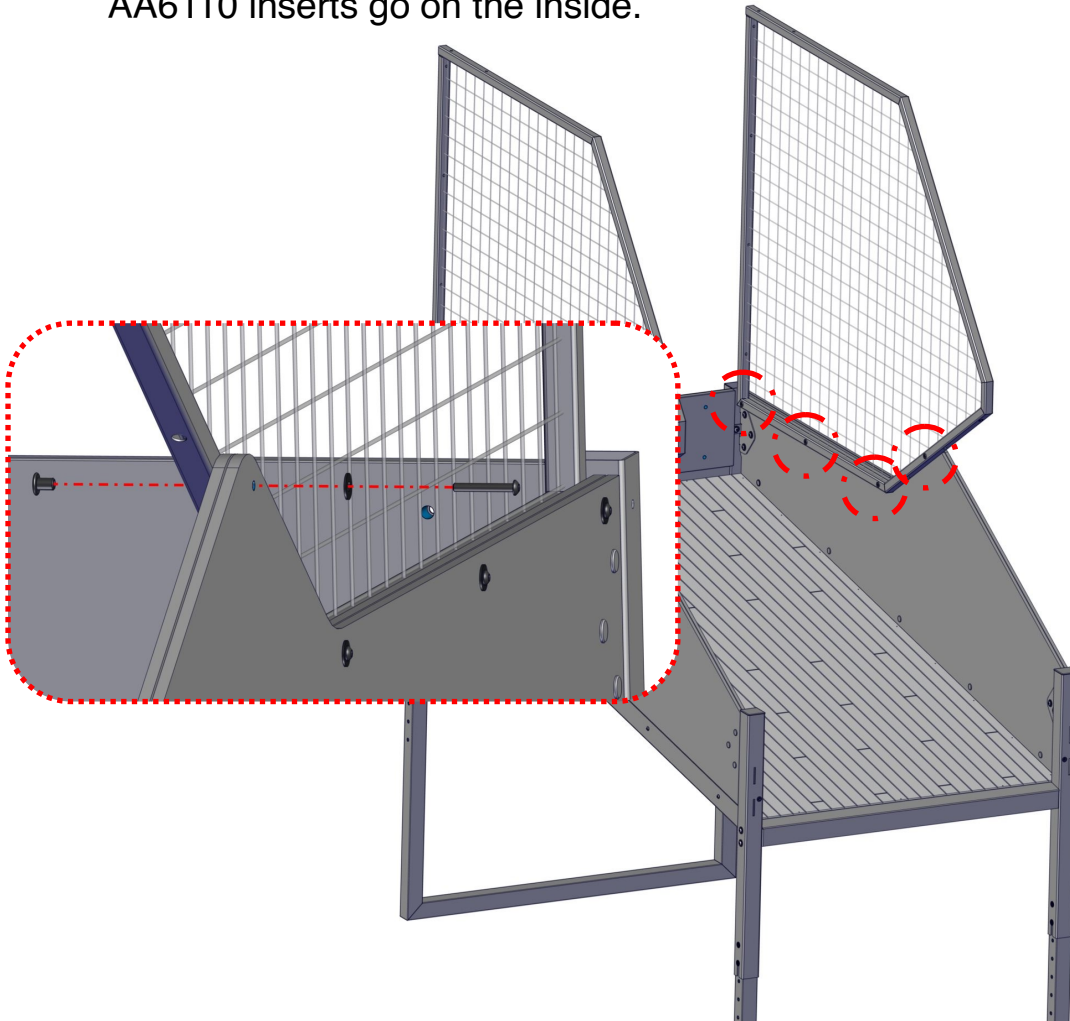

Slide net onto backboard assembly as shown.

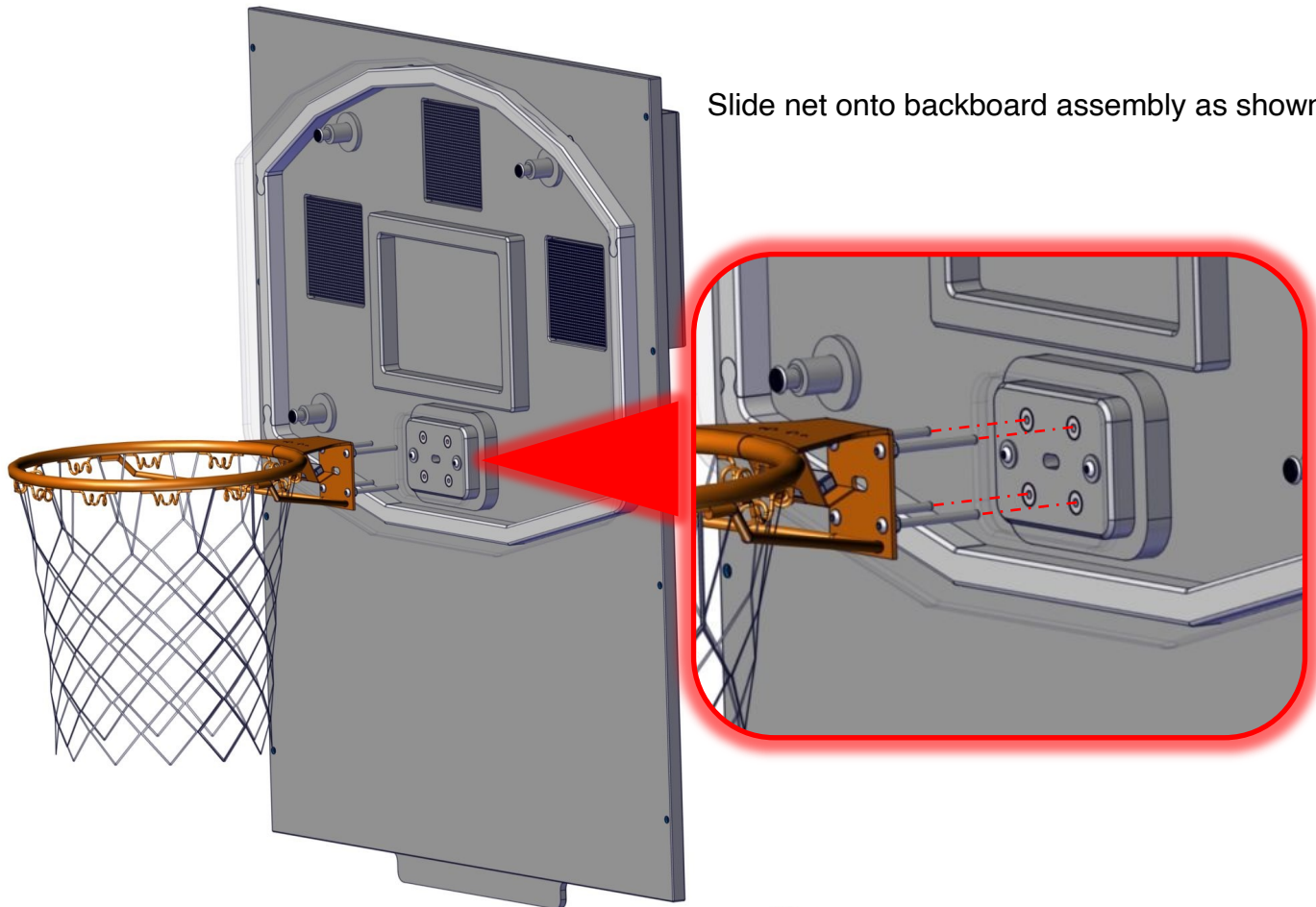

Basket

(4) PC60604 nylon nut

(4) AA6070 washer

Secure front using only 4 PC60604 bolts and 4 AA6070 washers

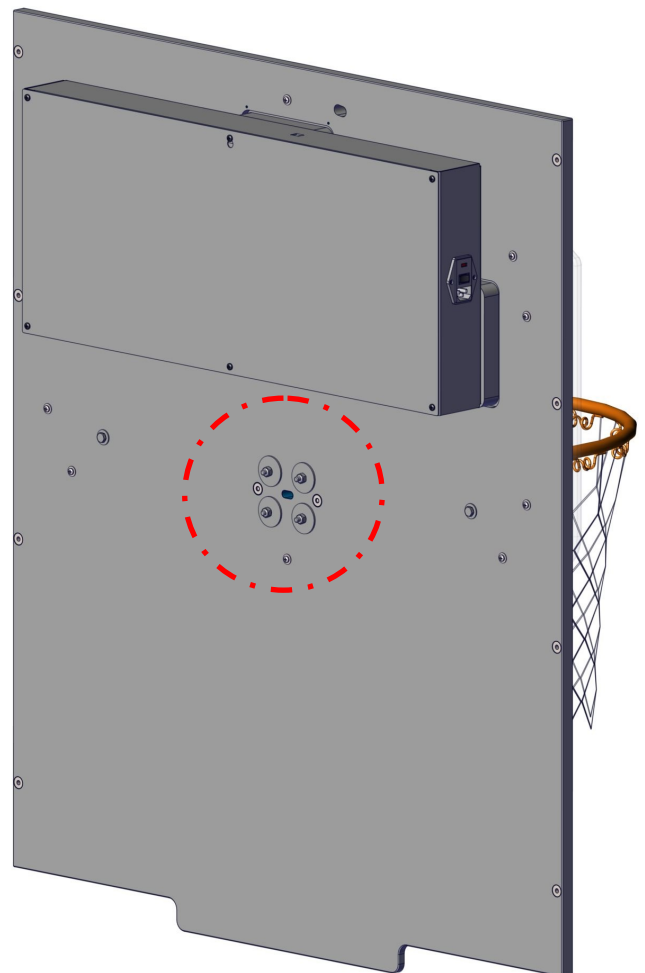

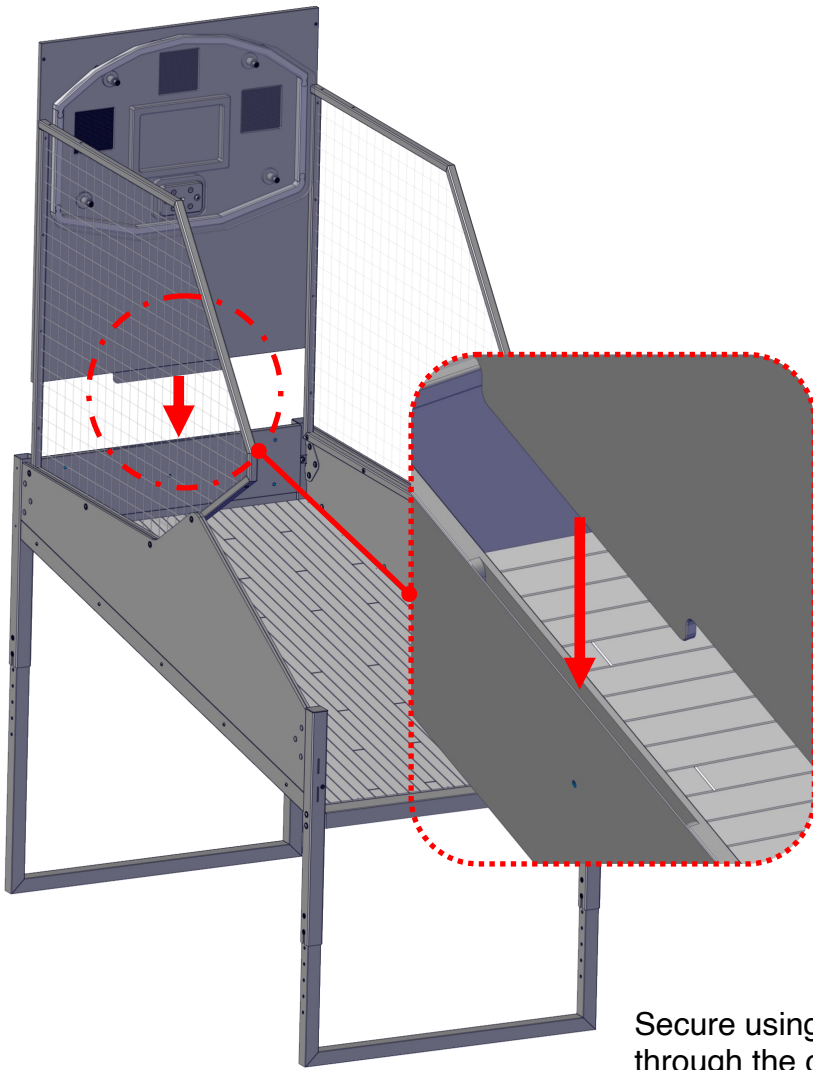

Back Board
(8) AA6220 bolt
(8) AA6430 washer

Insert back board into back slot.

Secure using AA6220 bolts and AA6430 washers through the cage into the back board.

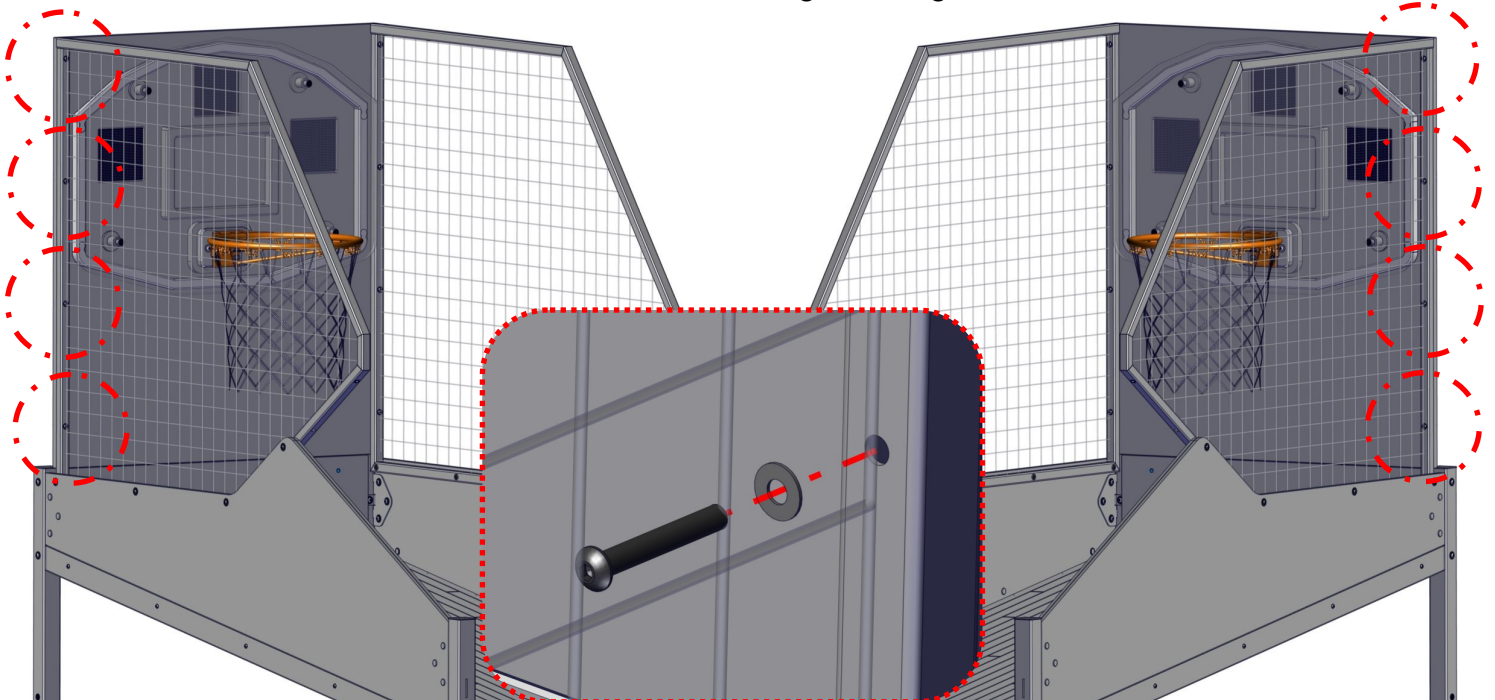

Secure sides using 2 AA6220 bolts at the sides and AA6430 washers.

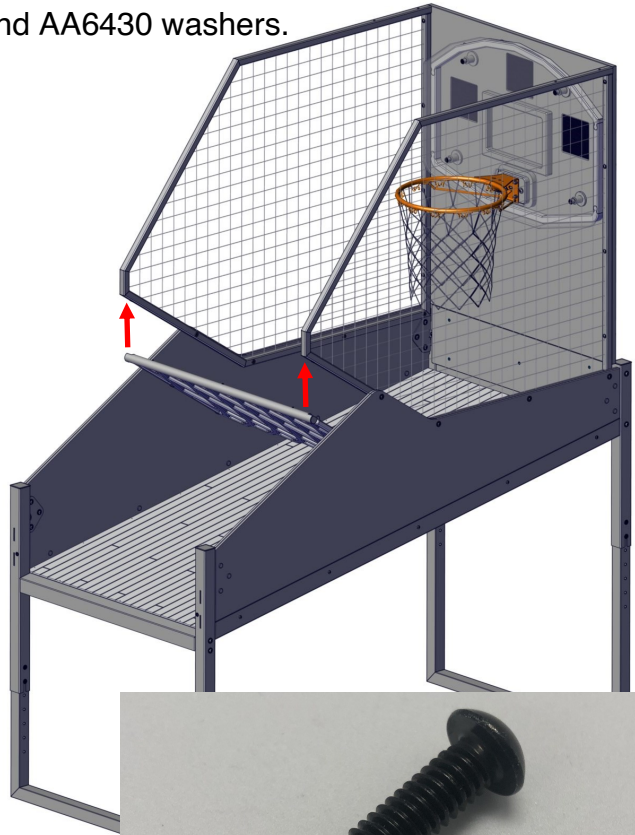
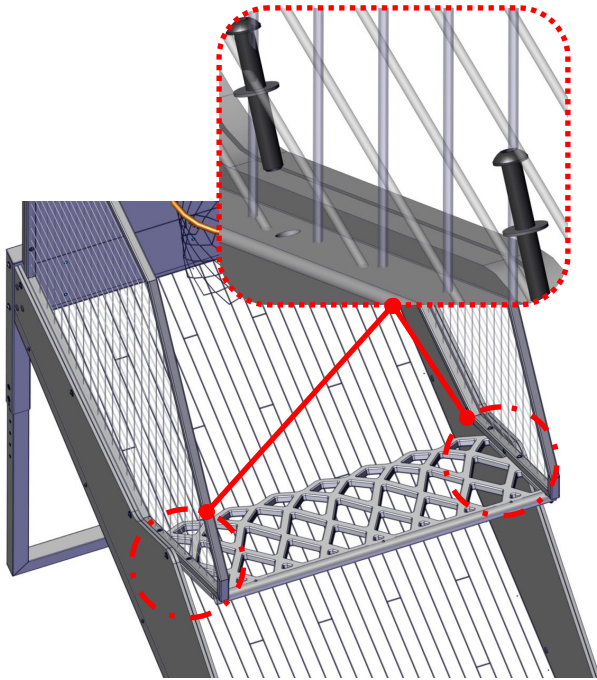

Secure front using only 2 AA6220 bolts (no washers)

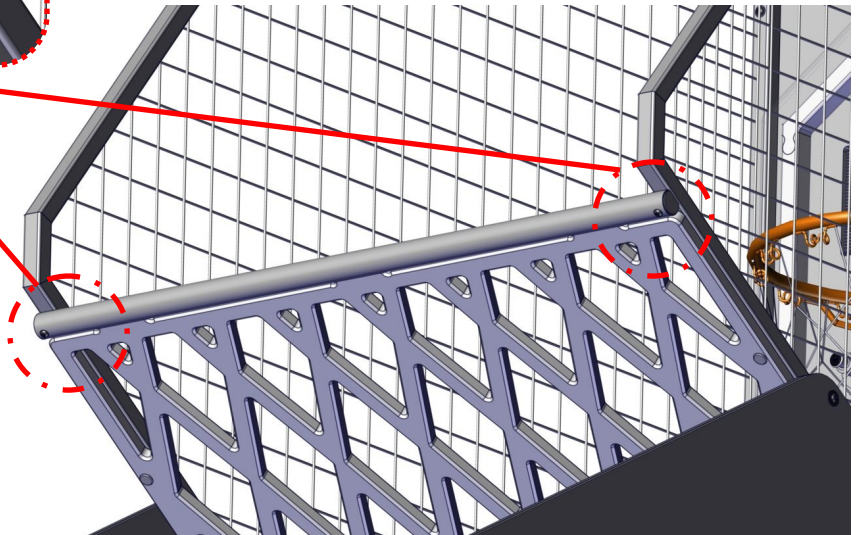
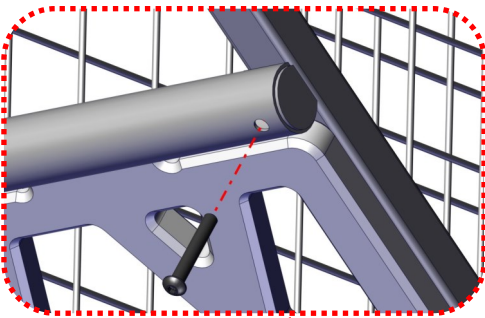

Place Cage Top at top.

From the bottom, insert 2 AA6281 Bolts and 2 AA6430 Washers on each side.

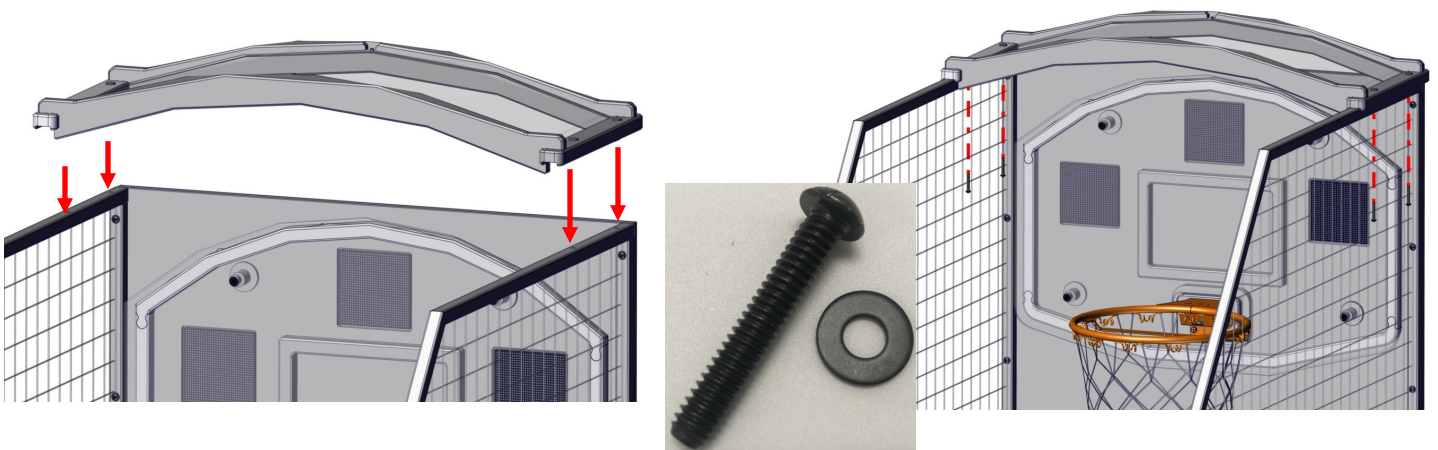

Standard Control Panel Install:

Insert the control panel into the slot and slightly push down to lock it in place.

Secure using 1 AA6718 bolt and 1 AA6212 washer on each side.

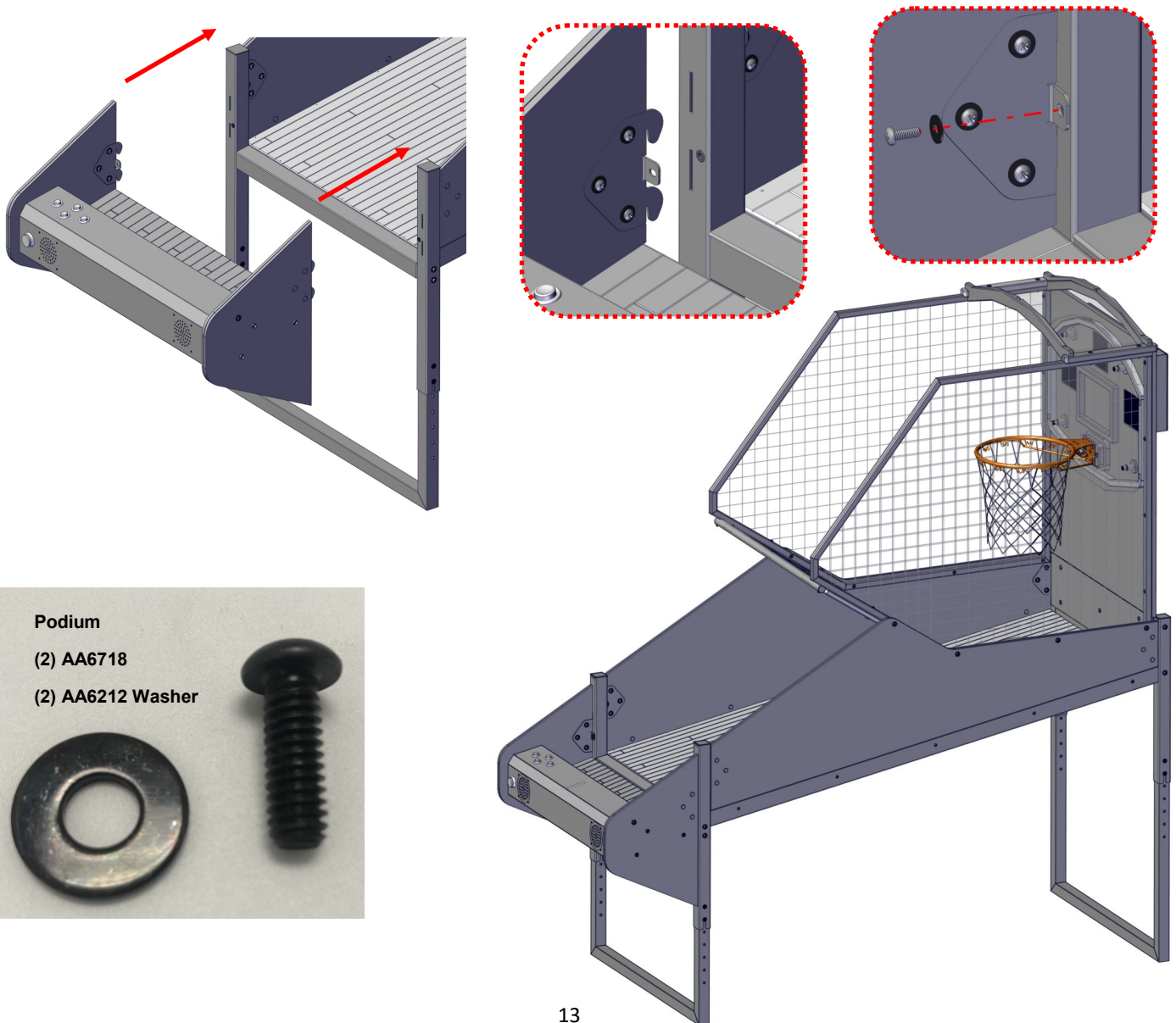

Optional Extended Control panel Install:

Insert the control panel into the slot and slightly push down to lock it in place.

Secure using 1 AA6718 bolt and 1 AA6212 washer on each side.

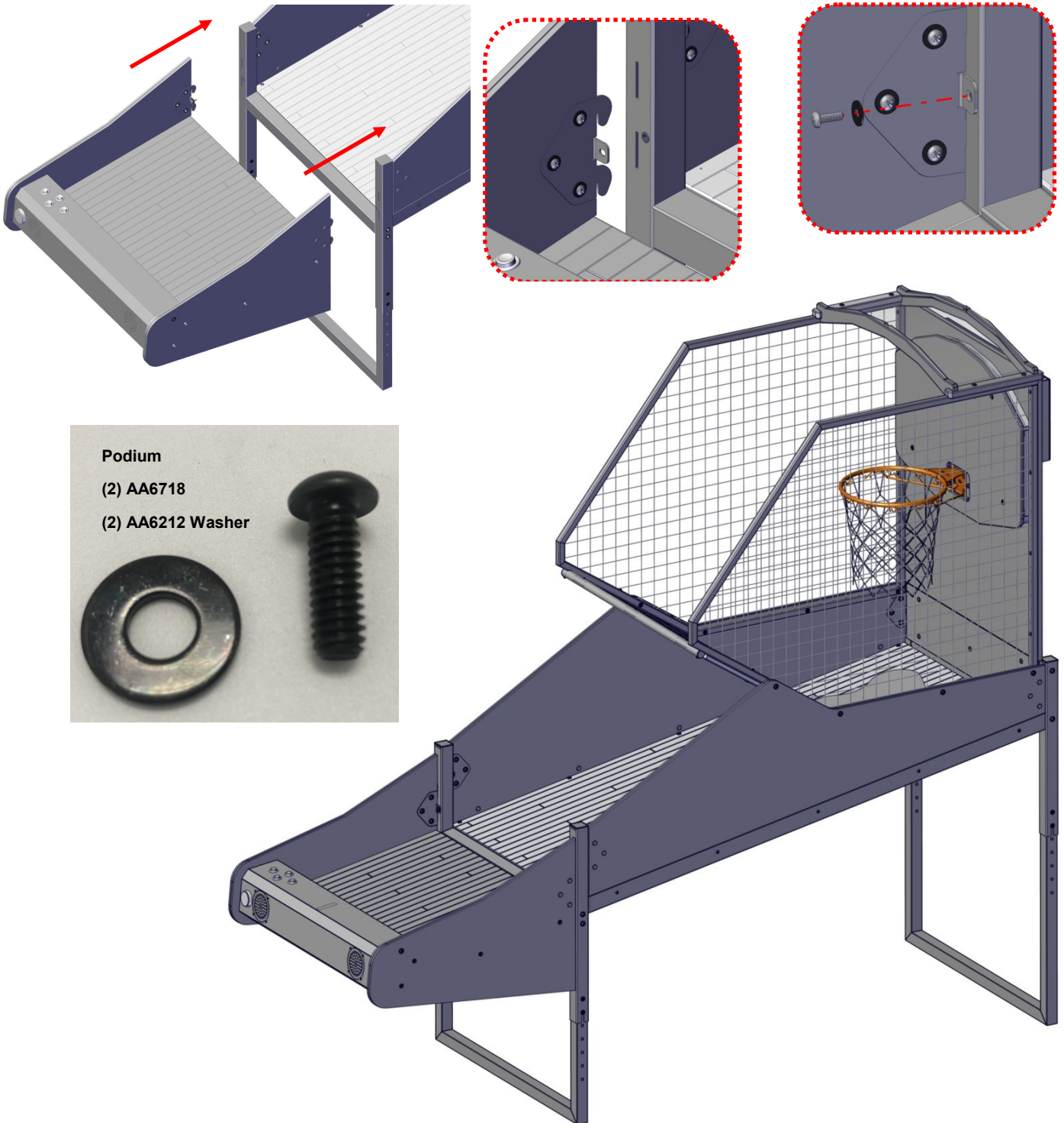

Podium

(2) AA6718

(2) AA6212 Washer

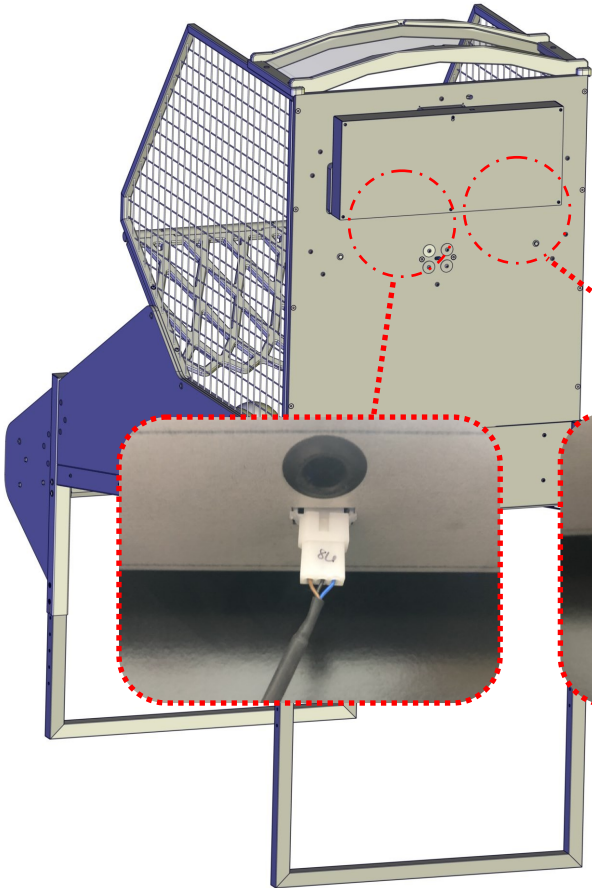

Plug main harness into back of game.
Plug Score Sensor harness into back of game.

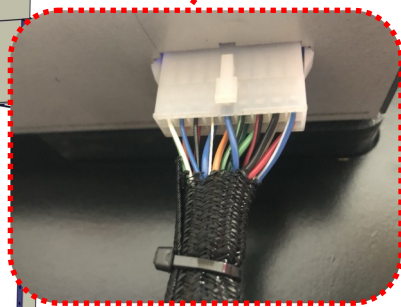

Plug main harness into control panel.
Plug AC cord at back side of game.

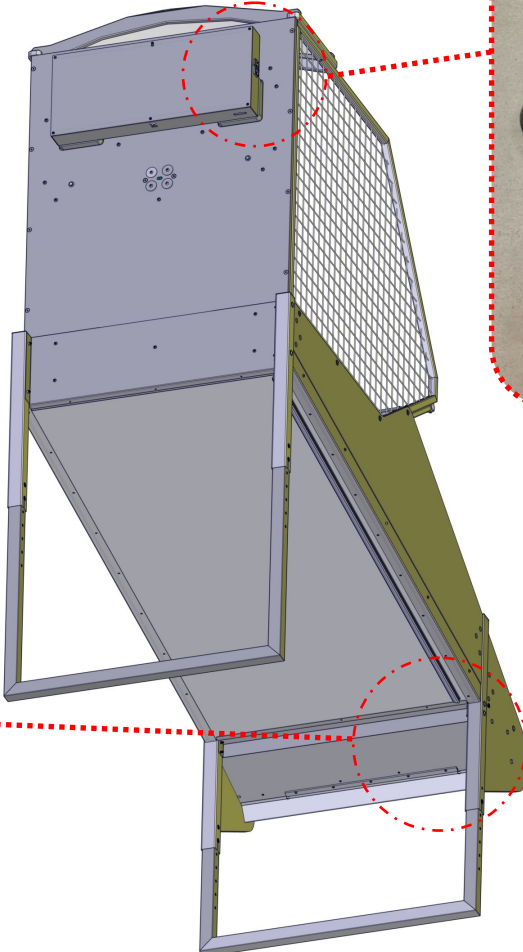

Insert the AC cord into a grounded AC outlet.
The cord can be found behind the back cabinet.

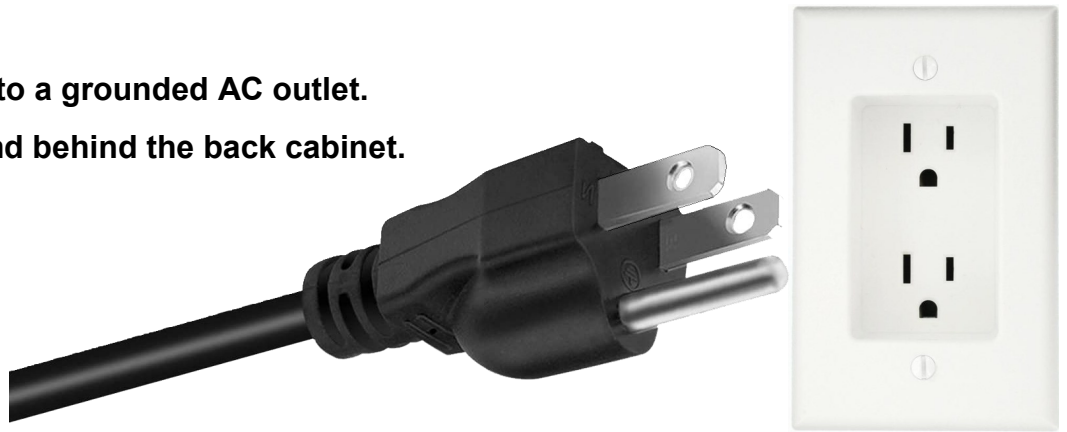

**WARNING - ONLY PLUG INTO A GROUNDED OUTLET.
DO NOT USE ADAPTORS THAT ELIMINATE THE THIRD PRONG!**

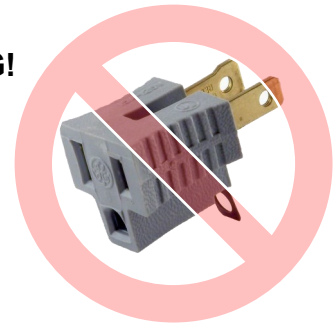

Flip the AC switch to the on position. It will have a “I” label.

Your game is ready to be played.

Press the “START” button to turn the game on.

The game will come to life.

There are four games and up to four players can play any of them. At anytime you can press either the “GAME” button or “PLAYER” button. Pressing the “GAME” button will cycle through the different games available. Pressing the player button will select how many players will play.

Once you have selected the game you wish to play and the amount of players that will play press the “START” button to begin play.

**** During game play, game volume can be adjusted by pressing the arrow keys. ****

GAME MODES



PRO – The classic basketball arcade game. Players race against the clock to score as many points as possible. Score 75 to get to the 2nd round. Score 100 to get to the 3rd (final) round. See who can get the all-time high score with this arcade classic.

Money Ball – Score points by making baskets – Race against the clock to score as many points as possible. Money signs are worth bonus points. \$ = 5 PTS, \$\$ = 10 PTS

Pig – The classic game takes on the arcade. Players take turn attempting shots. If a player misses, they get a P, they miss a second time I and the third time they miss they will get a G and be removed from the game. Last player standing wins. Creativity is key – off the side bank shot? Blind-folded?

Last Shot – Get as close to zero as possible. Timer counts down from three seconds. Each player gets four shots per game.

GAME OPTIONS

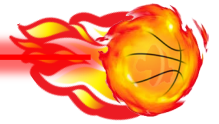

You can change some of the game options if you wish.

Pressing the left and right arrows buttons together will cause the game to display the options available for that game.

The arrow keys will change the value for that option displayed.

Pressing the “GAME” button will advance to the next option.

Pressing the “START” button will exit and save any changed you made.

Press the “GAME” button to select a different game and repeat this process.

The Game’s LED’s are controlled by the Accent color settings under PRO. These are the only options that effect all games. The remainder of the options are specific to that game only.

Pro: Settings

Round 2 Bonus

Default setting: 75 (Choices 30-120 increment by 5)

Round 3 Bonus now shows the Target (offset+Bonus set above)

Default 100

Choices 5-50+ bonus above so low of 35 and high of 170

Color 1

Default Red

Off-White

Color 2

Default Green

Off-White

Color 3

Default Blue

Off-White

Reset High Score

Rev

PIG: Settings

Rev

Money Ball: Settings

Game Time

Default 45

Choices 45 or 60

Reset High Score

Rev

Last Shot: Settings

Reset High Score

Rev

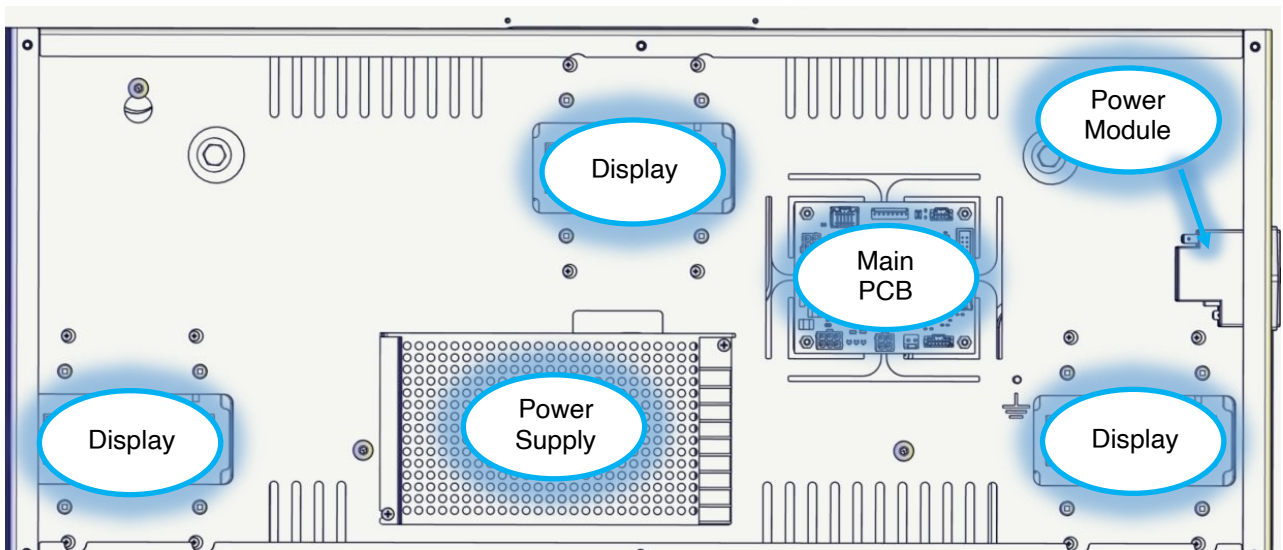
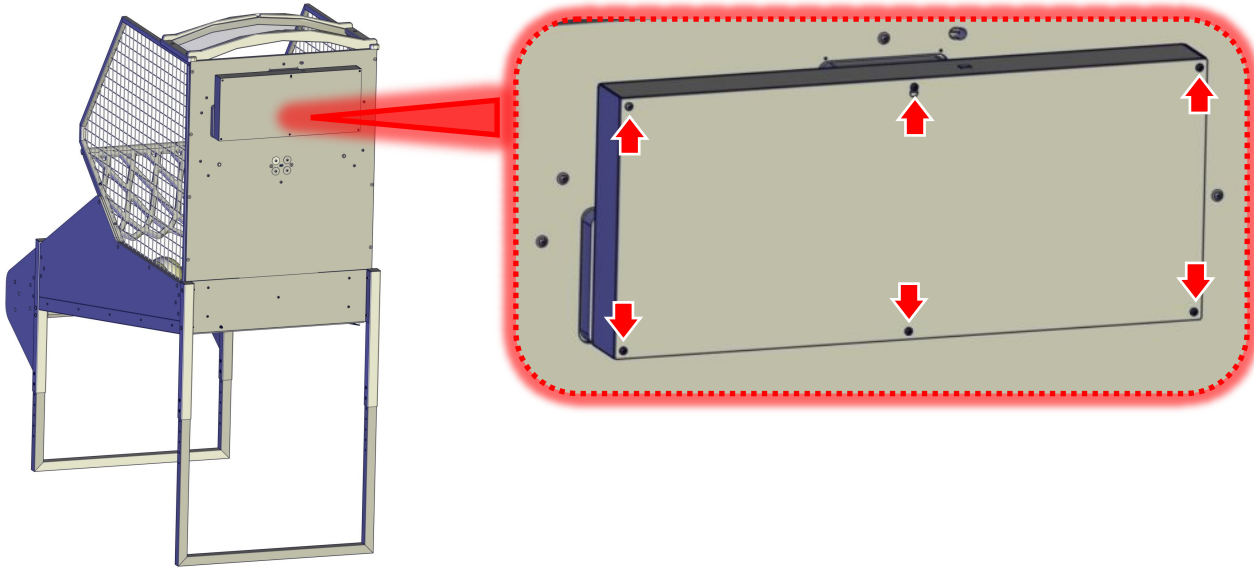
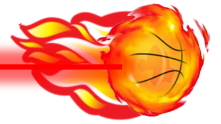

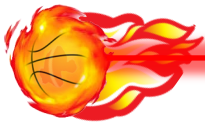

SCORE SENSOR

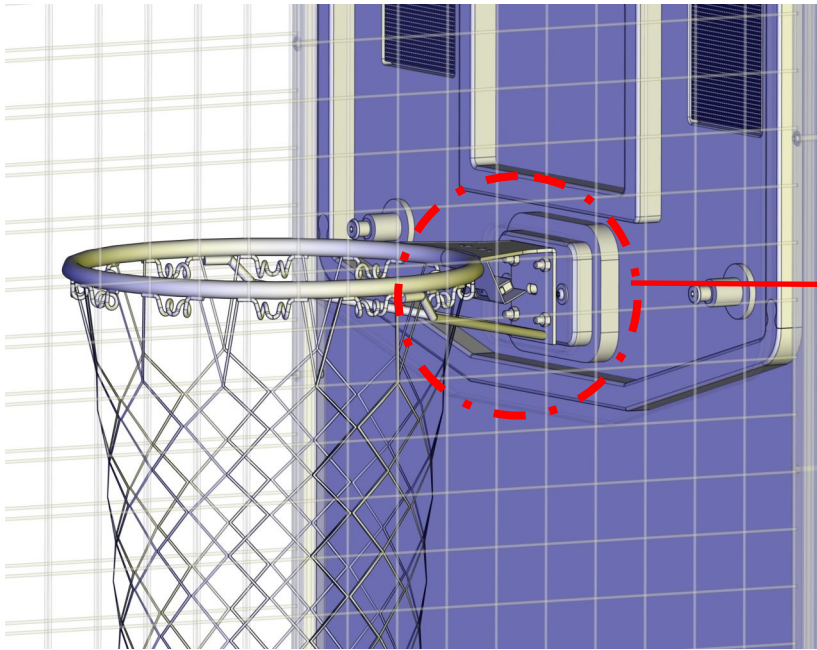

PART # E00210NSAX



MAIN BOARD CONNECTIONS

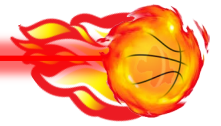

ID	Type	Pin	Description	Wire Color
J1	.100" 4-Pin Header Audio	1	Left (+)	RED/GRY
		2	Left (-)	BRN/GRY
		3	Right (+)	RED/WHT
		4	Right (-)	BRN/WHT
J3	.100" 8-Pin Header Buttons	1	+12VDC	ORG
		2	Start Light	YEL/BLU
		3	Start	GRY/BLU
		4	Player	WHT/BLU
		5	Game	WHT/VIO
		6	Up	WHT/GRY
		7	Down	WHT
		8	GND	BLK
J4	.165" 8-Pin Header Power In	1	PGND	BLK
		2	PGND	BLK
		3	GND	BLK
		4	GND	BLK
		5	+12VDC	ORG
		6	+12VDC	ORG
		7	+5VDC	RED
		8	+5VDC	RED
J6	.165" 6-Pin Header +5VDC out	1	GND	BLK
		2	GND	BLK
		3	GND	BLK
		4	+5VDC	RED
		5	+5VDC	RED
		6	+5VDC	RED
P4	.165" 4-Pin Header RGB Lights	1	Red	RED/BLK X 2
		2	Green	GRN/BLK X 2
		3	N/C	ORANGE X 2
		4	Blue	BLU/BLK X 2
P5	.079" 12-Pin Header Sensors	1	HOOP	GRY/RED
		2	GND	BLK
		3	N/C	-
		4	N/C	-
		5	N/C	-
		6	N/C	-
		7	N/C	-
		8	N/C	-
		9	N/C	-
		10	N/C	-
		11	N/C	-
		12	GND	-
P2	.100" 16-Pin Header	1-12	Displays	Ribbon Cable

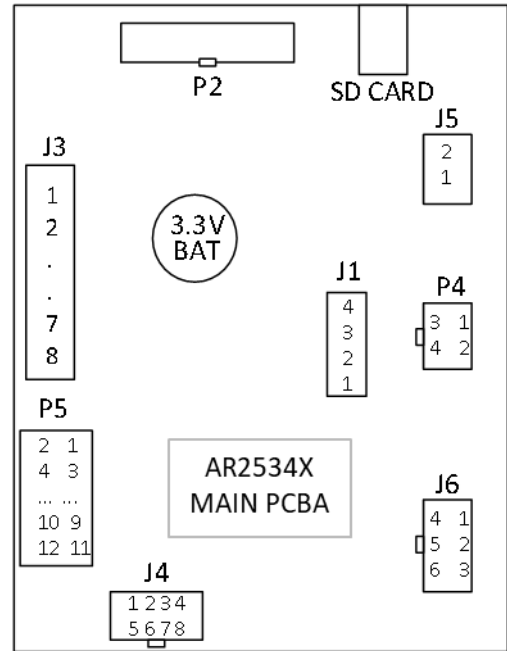



WARRANTY POLICY

I.C.E. Inc warrants all components in your new NBA Pro Home Edition machine to be free of defects in materials and workmanship for the period of **ONE YEAR** from purchase date.

I.C.E. Inc shall not be obligated to furnish a warranty request under the following conditions:

- The game is operated commercially.
- Equipment has been subjected to unwarranted stress, abuse or neglect.
- Equipment has been damaged as a result of arbitrary repair/modification.

Products will only be covered under warranty free of charge by obtaining an I.C.E. authorized RMA #. To obtain an RMA # please provide I.C.E. tech support with the game serial # or original I.C.E. invoice # and a detailed description of the failure or fault symptoms.

I.C.E. Inc will assume no liability whatsoever for costs associated with labor or travel time to replace defective parts. All defective warranty covered components will be replaced with new or factory refurbished components equal to OEM specifications.

I.C.E. Inc will cover domestic UPS ground, or comparable shipping costs during the warranty period. International or expedited shipments are available for an additional charge.

ICE distributors are independent, privately owned and operated. In their judgment, they may sell parts and/or accessories other than those manufactured by I.C.E. Inc. We cannot be responsible for the quality, suitability or safety of any non-I.C.E. part or modification (including labor) that is performed by such a distributor.

**Innovative Concepts in Entertainment
10123 Main St.**

Clarence, NY 14031

Phone #: (716) - 759 – 0360

Fax #: (716) – 759 – 0884

www.icegame.com